



GOVERNING BOARD MEETING

August 28, 2024

**Professional Development Building, Boardroom
1680 David E Cook Way, Clovis, California**

5:30 PM - CLOSED SESSION

6:30 PM - PUBLIC SESSION

Members of the public who wish to provide public comments must do so in-person during the Board meeting. **Please complete and submit a Public Comment Form before the start of the Public Session on the day of the meeting.** The Public Comment Form is available outside the Board meeting room on the day of the meeting. During the meeting, speakers who have requested to address the Board will be called to do so. Comments on items that are on the agenda are to be made when the item is called by the Board President. Comments on matters that are not on the agenda are to be made during the Public Presentations. Pursuant to Board Bylaw No. 9323, each speaker generally has up to 2 minutes to speak. The Board President may adjust the time allotted for each speaker and limit the total time for public comment. No speaker may yield his or her time to another speaker. Each regular Board meeting will be video recorded by the District, the recording of which will be made accessible to the public within 48 hours of the Board meeting at:

<https://www.cusd.com/BoardMeetingsAgendasArchives.aspx>

Regular Meeting AGENDA

Additional information regarding this agenda may be viewed through the District's website at <https://www.cusd.com/BoardMeetingsAgendasArchives.aspx>

In compliance with the Americans with Disabilities Act, if you need special assistance to access the Board meeting room or to otherwise participate at this meeting, including auxiliary aids or services, please contact the Superintendent's Office at 327-9100. Notification at least 48 hours prior to the meeting will enable the District to make reasonable arrangements to ensure accessibility to the Board meeting. Public records relating to an open session agenda item of a regular meeting that are distributed within 72 hours prior to the meeting will be available for public inspection at the District Office, 1450 Herndon Avenue, Clovis, California. An invocation may be held prior to the start of the Board meeting. Attendance during and participation in the invocation are optional and voluntary. No students, parents, members of the public, Board members, student Board representative, or employees are required to attend or participate in the invocation.

INVOCATION

A. CALL TO ORDER

B. ROLL CALL

C. ADOPTION OF AGENDA

D. CLOSED SESSION

1. CONFERENCE WITH LEGAL COUNSEL – ANTICIPATED LITIGATION – Significant Exposure to Litigation (Pursuant to Subdivision (d)(2) of Gov't. Code §54956.9) – 1 case
2. CONFERENCE WITH LEGAL COUNSEL – EXISTING LITIGATION (Gov't Code §54956.9(d)) - SA-CE-3040-E, SA-CE-3047-E, SA-CE-3051-E, OAH Case No. 2024080149, OAH Case No. 2024080470
3. CONFERENCE WITH LABOR NEGOTIATORS (Education Code §54957.6) Agency Negotiator – Corrine Folmer, Ed.D., Supt. Negotiating Parties – Contracted Emps., Cert. Mgmt., Cert. Teachers, Class. Emps., Class. Mgmt. and Ops. Unit (Represented by CSEA Clovis Chapter 250)
4. APPOINTMENT/EMPLOYMENT OF INDIVIDUALS IN POSITIONS LISTED IN BOARD POLICY EXHIBITS NO. 4151.10, 4251.10, 4351.10, 4151.21, 4151.22, 4151.23, AND 4251.10 (Gov't. Code §54957)
5. PUBLIC EMPLOYEE DISCIPLINE/DISMISSAL/RELEASE/SUSPENSION (Gov't. Code §54957)
6. STUDENT DISCIPLINE AND OTHER CONFIDENTIAL STUDENT MATTERS (Education Code §48900 et seq. and §35146)

E. RECONVENE FOR PUBLIC SESSION

F. RECOGNITION OF VISITORS

G. PLEDGE OF ALLEGIANCE

H. CLOSED SESSION MOTIONS

I. SUPERINTENDENT'S REPORT

J. SPECIAL PRESENTATIONS

1. Clovis East High School Musical Performance
Cast members from the Clovis East High School Theater Arts Program will be performing numbers from their upcoming production of "Guys & Dolls" under the direction of Heather Randall.
2. The City of Clovis Youth Commission
The Board will recognize Clovis Unified students who served on the 2023-24 City of Clovis Youth Commission.
3. Introduction of New Administrators
Newly appointed administrators will be introduced to members of the Governing Board.

K. PUBLIC PRESENTATIONS

This time is reserved for individuals who may wish to address the Board regarding a matter that is not included on the agenda. Please note that because the items brought up by the public during this time

are not on the agenda, the Governing Board may not discuss or act upon such items.

L. PUBLIC HEARINGS

1. Public Hearing Regarding the Conveyance of Public Utility Easement to Fresno Metropolitan Flood Control District, APNs 310-320-03ST, 310-320-05ST, 310-320-06ST, 310-050-38T

Conduct a public hearing no earlier than 6:45 p.m. at 1680 David E. Cook Way, Clovis, regarding the conveyance of a public utility easement to Fresno Metropolitan Flood Control District (FMFCD) for APNs 310-320-03ST, 310-320-05ST, 310-320-06ST and 310-050-38T.

M. STAFF REPORTS

1. 2024-25 Opening of School Report

Administrators will provide the Board with an update on the opening of the 2024-25 school year.

N. CONSENT

1. Conference Requests

Approve the Conference Requests, as submitted.

2. Fundraiser Requests

Approve the Fundraiser Requests, as submitted.

3. Student Trip Requests

Approve the Student Trip Requests, as submitted.

4. Voluntary Community Recreation Programs

Approve the Voluntary Community Recreation Programs, as submitted.

5. August 7, 2024, Governing Board Meeting Minutes

Approve the minutes of the August 7, 2024, Governing Board meeting, as submitted.

6. Ratification of Purchase Orders, District Contracts and Check Register

Ratify Purchase Orders, District Contracts, and Warrants numbered 679840 through 680627.

7. Change Orders

Approve the Change Orders, as submitted.

8. Approval of Early Admission to Kindergarten

Approve early admission to Kindergarten and determine that admittance is in the best interest of the child.

O. ACTION

In general (unless otherwise noted), these items were seen for Information at the prior Board meeting and will be voted on at this meeting. Agenda items titled "Annual" are recurring items submitted to the Board for approval yearly.

1. Extraterritorial Water, Sewer and Related Services and Offsite Infrastructure Agreement Between Clovis Unified School District and the City of Fresno

Approve the Extraterritorial Water, Sewer, and Related Services and Offsite Infrastructure Agreement (Agreement) between Clovis Unified School District and the City of Fresno relating to the Terry P. Bradley Educational Center, and authorize the Superintendent or designee to make such changes thereto as may be necessary or proper to finalize and execute the agreement with the City of Fresno.
2. Provisional Internship Permit

Approve the Provisional Internship Permit (PIP) for the recommended teaching candidates, as submitted.
3. Section 125 Amendment to Flexible Benefit Plan

Approve an amendment to the District's Section 125 Flexible Benefit Plan, as submitted.
4. Triennial Agreement with CommonLit

Authorize the Superintendent or designee to enter into an agreement with CommonLit, a webbased toolkit, effective for a three-year period for school years 2024-25, 2025-26, and 2026-27.
5. Action Mentoring Program Agreement for 2024-25

Approve the mentoring agreement with Action Mentoring Program (AMP), as submitted.
6. Annual California School Boards Association Membership

Should the Governing Board desire to maintain its membership in the California School Boards Association (CSBA) for the 2024-25 school year, it will be necessary for the Board to approve the payment of dues in the amount of \$26,289.
7. Annual Education Legal Alliance Membership

Should the Governing Board desire to obtain a membership in the Education Legal Alliance (ELA), it will be necessary for the Board to approve the payment of dues in the amount of \$6,572.
8. Resolution No. 4003 - Approving Conveyance of Easement to Fresno Metropolitan Flood Control District, APNs 310-320-03ST, 310-320-05ST, 310-320-06ST, 310-050-38T

Adopt Resolution No. 4003 approving the conveyance of an easement to Fresno Metropolitan Flood Control District (FMFCD) for installation of a storm drain and other incidental purposes regarding APNs 310-320-03ST, 310-320-05ST, 310-320-06ST and 310-050-38T (TWO THIRDS VOTE REQUIRED).
9. Resolution No. 4004 - Exemption to the Separation-from-Service Requirement for One Certificated Retiree

Adopt Resolution No. 4004, approving an exemption to the separation-from-service requirement for the 2024-25 school year (Education Code § 24214.5 or 26812).
10. Resolutions No. 4005 and 4006 - Exemptions to the Separation-from-Service Requirement for Two Classified Retirees

Adopt Resolutions No. 4005 and 4006 authorizing Clovis Unified School District to hire two CalPERS retirees prior to the 180-day post-retirement waiting period.
11. Award of Bid - Services

Award the following Request for Proposal (RFP) No 2998 - Charter Bus Services to various service providers.

P. INFORMATION

Unless otherwise noted, these items are on the agenda to provide time for Board members to review prior to taking action on the items at the next Board meeting. Agenda items titled "Annual" are recurring items submitted to the Board for approval yearly.

1. Annual Agreement with KEY2ED Professional Development

Authorize Clovis Unified School District to enter into an agreement with KEY2ED Professional Development for the purpose of utilizing their services to train staff in the Facilitated Individualized Education Plan Program.

2. Amended Board Policies No. 1312.2, 1312.3, 5030, 5111 and 6158

Adopt amended Board Policies No. 1312.2, 1312.3, 5030, 5111 and 6158.

3. Biennial AB 3141 Health and Benefits Actuarial

Disclosure Approve funding the projected 2023-24 retiree health and welfare benefit costs on an incurred "pay-as-you-go" basis with the understanding sufficient funds to cover annual costs have been included in the 2024-25 Budget.

4. Annual 2023-24 Financial Report

Accept the 2023-24 Annual Financial Report, as submitted.

5. Resolution No. 4008 – Annual Budget Transfers 2023-24

Adopt Resolution No. 4008 authorizing budget transfers for the 2023-24 fiscal year for funds operated by the District.

6. Resolution No. 4009 – Annual Recalculated 2023-24 Gann Limit Appropriation and Estimated 2024-25 Gann Limit Appropriation

Adopt Resolution No. 4009 to recalculate the 2023-24 Gann Limit Appropriation and estimate the 2024-25 Gann Limit Appropriation.

7. Award of Bid - Construction

A recommendation for Bid 2999 - Campus Security Improvements Phase III will be brought to the Governing Board for action at a future date.

Q. BOARD SUBCOMMITTEE REPORTS

1. Center for Advanced Research and Technology (CART) Board Meeting (Awtrey)

R. BOARD MEMBER REPORTS

S. ADJOURNMENT

CUSD Board Agenda Item

Agenda Item: J 1

Title: Clovis East High School Musical Performance

CONTACT: Marc Hammack

FOR INFORMATION: August 28, 2024

FOR ACTION: August 28, 2024

RECOMMENDATION:

Cast members from the Clovis East High School Theater Arts Program will be performing numbers from their upcoming production of "Guys & Dolls" under the direction of Heather Randall.

DISCUSSION:

FISCAL IMPACT:

REVISIONS:

ATTACHMENTS:

Description

Upload Date

CUSD Board Agenda Item

Agenda Item: J 2

Title: The City of Clovis Youth Commission

CONTACT: Marc Hammack

FOR INFORMATION: August 28, 2024

FOR ACTION: August 28, 2024

RECOMMENDATION:

The Board will recognize Clovis Unified students who served on the 2023-24 City of Clovis Youth Commission.

DISCUSSION:

FISCAL IMPACT:

REVISIONS:

ATTACHMENTS:

Description

Upload Date

CUSD Board Agenda Item

Agenda Item: J 3

Title: Introduction of New Administrators

CONTACT: Norm Anderson

FOR INFORMATION: August 28, 2024

FOR ACTION: August 28, 2024

RECOMMENDATION:

Newly appointed administrators will be introduced to members of the Governing Board.

DISCUSSION:

The following newly appointed administrators will be recognized during the August 28, 2024, Governing Board meeting:

- Karen Majchen, Principal, Mickey Cox Elementary School
- Jason James, Principal, Clovis West High School
- Matthew Loggins, Deputy Principal, Clovis West High School

FISCAL IMPACT:

REVISIONS:

ATTACHMENTS:

Description

Upload Date

CUSD Board Agenda Item

Agenda Item: L 1

Title: Public Hearing Regarding the Conveyance of Public Utility Easement to Fresno Metropolitan Flood Control District, APNs 310-320-03ST, 310-320-05ST, 310-320-06ST, 310-050-38T

CONTACT: Michael Johnston

FOR INFORMATION: August 28, 2024

FOR ACTION: August 28, 2024

RECOMMENDATION:

Conduct a public hearing no earlier than 6:45 p.m. at 1680 David E. Cook Way, Clovis, regarding the conveyance of a public utility easement to Fresno Metropolitan Flood Control District (FMFCD) for APNs 310-320-03ST, 310-320-05ST, 310-320-06ST and 310-050-38T.

DISCUSSION:

Clovis Unified School District ("District") owns the real property located at 2501 N. Highland Ave., Fresno, CA 93727, in the County of Fresno, and bearing Fresno County Assessor's Parcel Numbers 310-320-03ST, 310-320-05ST, 310-320-06ST, and 310-050-38T ("Property"). The District has undertaken a public works project to design and construct a new educational center including a high school and an intermediate school ("Project") on the Property. A portion of the Project is anticipated to be completed by August 2025.

The purpose of the proposed easement is to grant FMFCD access to the Property to install, construct, operate, maintain, repair, remove and replace an underground storm drainage pipeline and to conduct water through the same, including a right of ingress thereto and egress therefrom. The proposed easement would prohibit the construction of any structures within the easement area, including buildings, roof overhangs and swimming pools. The proposed Deed of Easement is attached.

Pursuant to Education Code section 17557, the Board adopted on August 7, 2024, a resolution declaring its intention to convey the easement to FMFCD and set a public hearing for this August 28, 2024, meeting. The Board will also be presented with a resolution to approve the conveyance of the easement to FMFCD.

FISCAL IMPACT:

No fiscal impact.

REVISIONS:

ATTACHMENTS:

Description

Upload Date

Item_No._3._2024-08-28__Notice_of_Public_Hearing_-
_Conveyance_of_Right_of_Way_Easement_to_FMFCF.pdf
Easement.pdf

11-07-2024

11-07-2024

NOTICE OF PUBLIC HEARING

CONVEYANCE OF UTILITY EASEMENT TO FRESNO MUNICIPAL FLOOD CONTROL DISTRICT APNs 310-320-03ST, 310-320-05ST, 310-320-06ST, 310-050-38T FRESNO, CALIFORNIA

The Governing Board of the Clovis Unified School District (District) will **hold a public hearing on August 28, 2024, no earlier than 6:45 p.m.**, upon the question of making the dedication or conveyance of an utility easement to Fresno Municipal Flood Control District on a portion of the real property located at 2501 N. Highland Avenue, City of Fresno, County of Fresno, State of California and designated as APNs 310-320-03ST, 310-320-05ST, 310-320-06ST, 310-050-38T. The purpose of the conveyance of the easement is to install, construct, operate, maintain, repair, remove and replace an underground storm drainage pipeline and to conduct water through the same, including a right of ingress thereto and egress therefrom.

The public hearing will be held at the following location:

Professional Development Building, Boardroom
1680 David E. Cook Way
Clovis, CA 93611

**RECORDING REQUESTED BY
FRESNO METROPOLITAN
FLOOD CONTROL DISTRICT**

**AND WHEN RECORDED RETURN TO:
FRESNO METROPOLITAN
FLOOD CONTROL DISTRICT
5469 East Olive Avenue
FRESNO, CALIFORNIA 93727**

**--NO FEE--
Benefit of Fresno Metropolitan
Flood Control District
Pursuant to Government Codes § 6103 and 27383**

SPACE ABOVE THIS LINE FOR RECORDERS USE ONLY

GRANT OF EASEMENT AND RIGHT-OF-WAY

THIS GRANT OF EASEMENT AND RIGHT-OF-WAY, is made and entered into this ___ day of _____, 20___ by and between Clovis Unified School District, a California unified school district, as Grantor, and Fresno Metropolitan Flood Control District, a California public corporation in the County of Fresno, State of California, as Grantee.

WITNESSETH

That Grantor, for good and valuable consideration, does hereby grant to Grantee a perpetual and exclusive easement in, through, over, and under that real property in the County of Fresno, State of California described in Exhibit "A" (the "Easement"), attached hereto and incorporated herein by this reference, to install, construct, operate, maintain, repair, remove and replace an underground storm drainage pipeline and to conduct water through the same, together with all rights necessary, convenient or incidental thereto, including a right of ingress thereto and egress therefrom over Grantor's property as described in Exhibit "B" hereto (the "Property"), provided that such access shall not unreasonably interfere with Grantor's enjoyment of the Property.

No structures (including, but not limited to, buildings, roof overhangs and swimming pools) shall be constructed within the Easement, and no trees may be planted therein, but shrubs and grasses may be planted and sidewalks and parking areas may be installed on the Easement. In the event the Grantee damages improvements thereto in the use of reasonable care and enjoyment of the Easement, it shall not be obligated to restore the same or be liable for any damages whatsoever related thereto.

This Easement shall “run with the land” and be binding upon and inure to the benefit of Grantor’s heirs, executors, administrators, assigns and successors.

IN WITNESS WHEREOF, Grantor has executed this Grant of Easement and Right-of-Way the day and year first above written.

“GRANTOR”
Clovis Unified School District,
a California unified school district

Michael Johnston
Associate Superintendent
Administrative Services

Date

EXHIBIT "A"

LEGAL DESCRIPTION OF STORM DRAIN EASEMENT

APN: 310-320-03ST

APN: 310-320-05ST

APN: 310-320-06ST

APN: 310-050-38T

That portion of the North half of the Southeast quarter of Section 25, Township 13 South, Range 21 East, Mount Diablo Base and Meridian, County of Fresno, State of California, more particularly described as follows:

COMMENCING at the East quarter corner of said Section 25;

Thence along the east line of said Southeast quarter, South 00° 19' 00" West, a distance of 733.97 feet;

Thence North 90° 00' 00" West, a distance of 52.00 feet to the **TRUE POINT OF BEGINNING**;

Thence North 90° 00' 00" West, a distance of 1173.42 feet;

Thence South 45° 00' 00" West, a distance of 108.14 feet;

Thence North 90° 00' 00" West, a distance of 1286.57 feet;

Thence North 01° 10' 48" East, a distance of 30.01 feet;

Thence North 90° 00' 00" East, a distance of 1273.52 feet;

Thence North 45° 00' 00" East, a distance of 108.14 feet;

Thence North 90° 00' 00" East, a distance of 1172.02 feet to a line being parallel with and 66.00 feet west of said east line;

Thence along said parallel line, South 00° 19' 00" West, a distance of 1.70 feet;

Thence South 44° 49' 39" East, a distance of 19.75 feet to a line parallel with and 52.00 feet west of said east line;

Thence along said parallel line, South 00° 19' 00" West, a distance of 14.30 feet to the **TRUE POINT OF BEGINNING**.

Containing 1.766 acres more or less.

L:\PROJECTS\2021\210323\ACAD\LEGALS\ON-SITE EASEMENT\02-DWG\210323-ONSITE_EX-C.DWG 7/19/2024 9:38 AM

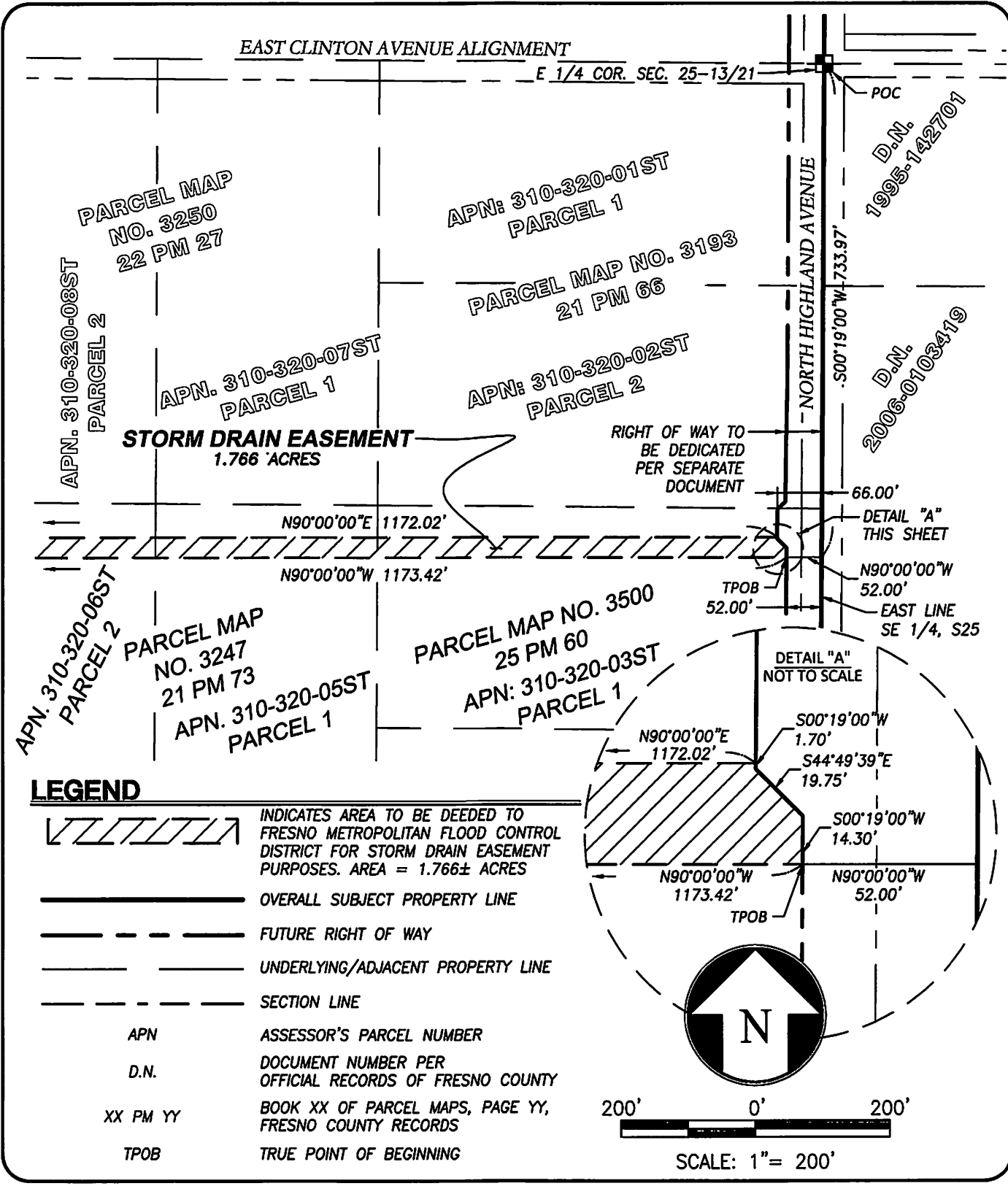

PROJECT NO.: 210323
DRAWN BY: GAI
QA/QC BY: ASW
SCALE: AS SHOWN
PAGE NO.:
2 of 3

EXHIBIT "A"
STORM DRAIN EASEMENT



L:\PROJECTS\2021\210323\ACAD\LEGALS\ON-SITE EASEMENT\02-DWG\210323-ONSITE_EX-C.DWG 7/19/2024 9:36 AM

EAST CLINTON AVENUE ALIGNMENT

NORTH LEONARD AVENUE

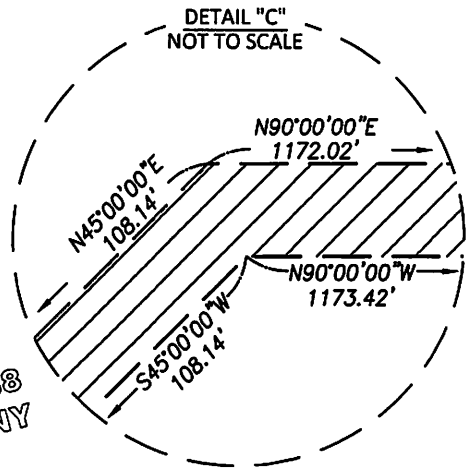
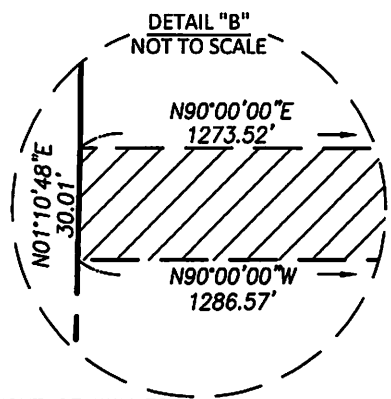

RIGHT OF WAY TO BE DEDICATED PER SEPARATE DOCUMENT

APN. 310-050-38
KUTNER COLONY
02 RS 08
LOT 8

WEST LINE LOT 7

STORM DRAIN EASEMENT
1.766 ACRES



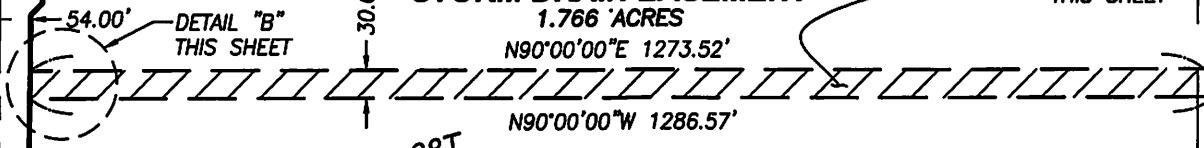

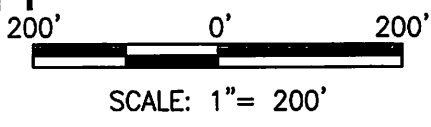

DETAIL "C" THIS SHEET



APN: 310-050-38T
KUTNER COLONY
02 RS 08
LOT 7



LEGEND

-  INDICATES AREA TO BE DEEDED TO FRESNO METROPOLITAN FLOOD CONTROL DISTRICT FOR STORM DRAIN EASEMENT PURPOSES. AREA = 1.766± ACRES
-  OVERALL SUBJECT PROPERTY LINE
-  FUTURE RIGHT OF WAY
-  UNDERLYING/ADJACENT PROPERTY LINE
-  EXISTING RIGHT OF WAY
-  SECTION LINE
- APN ASSESSOR'S PARCEL NUMBER
- D.N. DOCUMENT NUMBER PER OFFICIAL RECORDS OF FRESNO COUNTY.
- 02 RS 08 BOOK 02 OF RECORD OF SURVEY, PAGE 08 FRESNO COUNTY RECORDS.
- TPOB TRUE POINT OF BEGINNING

PROJECT NO.: 210323
 DRAWN BY: GAI
 QA/QC BY: ASW
 SCALE: AS SHOWN
 PAGE NO.:
3 OF 3

EXHIBIT "A"

STORM DRAIN EASEMENT



WWW.QKINC.COM
 1-800-855-7599
 BAKERSFIELD, CLOVIS, HANFORD, MERCED, PORTERVILLE, VISALIA
 © COPYRIGHT BY QUAD KNOPF, INC. UNAUTHORIZED USE PROHIBITED.

EXHIBIT "B"

LEGAL DESCRIPTION OF PROPERTY

Those portions of the North half of the Southeast quarter of Section 25, Township 13 South, Range 21 East, Mount Diablo Base and Meridian, in the County of Fresno, State of California, more particularly described as follows:

Parcel No. 1 of Parcel Map No. 3500, according to the map thereof recorded in Book 25 Page 60 of Parcel Maps, Fresno County Records.

TOGETHER WITH Parcel No. 1 of Parcel Map No. 3247, according to the map thereof recorded in Book 21 Page 73 of Parcel Maps, Fresno County Records.

TOGETHER WITH Parcel No. 2 of Parcel Map No. 3247, according to the map thereof recorded in Book 21 Page 73 of Parcel Maps, Fresno County Records.

TOGETHER WITH Lots 7 & 8 of Kutner Colony according to the map thereof recorded in Book 2 at Page 8, of Record of Surveys, Fresno County Records.

CUSD Board Agenda Item

Agenda Item: M 1

Title: 2024-25 Opening of School Report

CONTACT: Norm Anderson

FOR INFORMATION: August 28, 2024

FOR ACTION: August 28, 2024

RECOMMENDATION:

Administrators will provide the Board with an update on the opening of the 2024-25 school year.

DISCUSSION:

The following administrators will be present to give the Board an update on the opening of the 2024-25 school year:

- Scott Dille, Ed.D., Assistant Superintendent, Clovis Area
- Kristen Belknap, Ed.D., Assistant Superintendent, Clovis West Area
- Steve France, Assistant Superintendent, Educational Services
- Kevin Kerney, Assistant Superintendent, Buchanan Area
- Jennifer Thomas, Assistant Superintendent, Clovis East Area
- Darin Tockey, Assistant Superintendent, Clovis North Area
- Stephanie Hanks, Ed.D., Assistant Superintendent, Clovis South Area
- Monica Flores, Assistant Superintendent, Instructional Services
- Erin Waer, Assistant Superintendent, Curriculum, Instruction & Accountability
- Susan Rutledge, Assistant Superintendent, Business Services
- Denver Stairs, Assistant Superintendent, Facility Services
- Roxanne Braswell, Chief Human Resources Officer
- Norm Anderson, Deputy Superintendent
- Marc Hammack, Ed.D., Associate Superintendent, School Leadership

FISCAL IMPACT:

REVISIONS:

ATTACHMENTS:

Description

Upload Date

CUSD Board Agenda Item

Agenda Item: N 1

Title: Conference Requests

CONTACT: None

FOR INFORMATION:

FOR ACTION:

RECOMMENDATION:

Approve the Conference Requests, as submitted.

DISCUSSION:

Attached are the Conference Requests submitted for Board approval.

FISCAL IMPACT:

N/A

REVISIONS:

ATTACHMENTS:

Description

Upload Date

CUSD Board Agenda Item

Agenda Item: N 2

Title: Fundraiser Requests

CONTACT: Marc Hammack

FOR INFORMATION:

FOR ACTION:

RECOMMENDATION:

Approve the Fundraiser Requests, as submitted.

DISCUSSION:

Attached are the Fundraiser Requests submitted for Board approval.

FISCAL IMPACT:

N/A

REVISIONS:

ATTACHMENTS:

Description

Upload Date

[8.28.2024_Fundraiser_Requests.pdf](#)

11-07-2024

**Clovis Unified School District
Fundraiser Requests 8.28.2024**

#	Site	Advisor	Start	End	Organization	Description	Vendor
9517	Fancher Creek	Carisa Cordova	3/24/2025	4/11/2025	PTC	Carnivals*	Costco, Kona Ice, Dog House Grill, Me-n-Ed's,
9814	Hirayama Elem	Laura Reynolds	8/30/2024	6/6/2025	PTC	Game Night *	Walmart
9815	Hirayama Elem	Laura Reynolds	8/30/2024	6/6/2025	PTC	Donuts with Dad	Larson Brothers Photography, Judy's Donuts
9816	Hirayama Elem	Laura Reynolds	8/30/2024	6/6/2025	PTC	Movie Nights*	Walmart, Little Caesars
9817	Hirayama Elem	Laura Reynolds	8/30/2024	6/6/2025	PTC	Family Dance	Larson Brothers Photography, Walmart
9818	Hirayama Elem	Laura Reynolds	8/30/2024	6/6/2025	ASB	Various "A-thons" (ie. Jog-A-Thons, Basketball Shoot-	Walmart
9819	Hirayama Elem	Laura Reynolds	8/30/2024	6/6/2025	PTC	Sunrise with Sons	Walmart, Larson Brothers Photography
9820	Hirayama Elem	Laura Reynolds	8/30/2024	6/6/2025	PTC	Carnivals*	Dutch Bros. Coffee, Kona Ice, Bounce House
9822	Mickey Cox Elem	Jeremy Dirks	8/29/2024	6/6/2025	PTC	Spirit Wear/Spirit Packs	Spirit Gear Direct
9823	Clark Inter	Chris Watson	8/29/2024	6/6/2025	Instrumental Music	Family Restaurant Night*	Habit Burger Grill, Chipotle Mexican Grill, Bobby Salazar's, Panda Express, McDonald's, Panera
9824	Freedom Elem	Cassie German	8/29/2024	6/30/2025	PTC	Spirit Wear/Spirit Packs	Artworkz, Patches Outlet, Simply Print Goods
9826	Hirayama Elem	Laura Reynolds	8/30/2024	6/6/2025	ASB	Book Fair	Scholastic Book Fair
9827	CNEC	Miranda Rudolph	8/29/2024	6/6/2025	Class of 2025	Food Truck*	Travelin' Tom's Coffee Truck, Dutch Bros. Coffee,
9828	CNEC	Miranda Rudolph	8/29/2024	6/6/2025	Class of 2025	Donations to Program	RevTrak
9829	CNEC	Miranda Rudolph	8/29/2024	6/6/2025	ASB	Spirit Wear/Spirit Packs	Ink Dab
9830	Cedarwood Elem	Chrissy Wilken	8/29/2024	6/6/2025	ASB	Virtual "A-Thons" (ie.,	Booster
9831	CNEC	Courtney Dale	8/29/2024	6/30/2025	Softball	Adult Dinners/Dance (ie. BBQs, crab feasts)*	Classic Catering

*In compliance with Board Policy 3554.

**Clovis Unified School District
Fundraiser Requests 8.28.2024**

9832	CNEC	Courtney Dale	8/29/2024	6/30/2025	Softball	Family Restaurant Night*	Chipotle Mexican Grill
9833	CNEC	Courtney Dale	8/29/2024	6/30/2025	Softball	Candy Sales*	World's Finest Chocolates

*In compliance with Board Policy 3554.

CUSD Board Agenda Item

Agenda Item: N 3

Title: Student Trip Requests

CONTACT: None

FOR INFORMATION:

FOR ACTION:

RECOMMENDATION:

Approve the Student Trip Requests, as submitted.

DISCUSSION:

Attached are the Student Trip Requests submitted for Board approval.

FISCAL IMPACT:

N/A

REVISIONS:

ATTACHMENTS:

Description

Upload Date

Title: Voluntary Community Recreation Programs

CONTACT: Marc Hammack

FOR INFORMATION:

FOR ACTION:

RECOMMENDATION:

Approve the Voluntary Community Recreation Programs, as submitted.

DISCUSSION:

The Clovis Community Sports and Recreation Department provides and operates noneducational, athletic and recreation programs and activities for the access and enjoyment of Clovis and surrounding communities. Such noneducational, recreational programs and activities are not part of the District’s curricular, extracurricular, or co-curricular educational programs, and are entirely separate and distinct from the District’s educational program. The Department’s recreational offerings are available to all age-appropriate participants in Clovis, Fresno and surrounding communities, whether or not such participants are enrolled in the District’s educational program, and students enrolled in the District’s educational program are never required to participate in the Department’s noneducational, recreational programs or activities.

The proposed costs listed below are to attend the camp/clinic and may not include additional items such as spirit packs, shirts, jerseys, etc. The additional items will be provided at cost with no profit for the program. All additional items will be specifically identified in the flyers to the community.

Clovis Community Sports and Recreation Department
Elementary Cheer and Dance Camp
Clovis North High School
Date: August 31, 2024
Grade: 4-6
Cost: \$25.00 per participant

Clovis Community Sports and Recreation Department
Fall Chaos AAU Girls Basketball
Clovis West High School
Date: September 1 - October 31, 2024
Grade: 4-12
Cost: \$125.00 per participant

Clovis Community Sports and Recreation Department
Badminton Workouts / Open Gym
Clovis North High School
Date: September 1 - December 15, 2024
Grade: 7-12

Cost: \$0

Clovis Community Sports and Recreation Department
Iron Eagles Wrestling Club
Clovis West High School
Date: September 3 - October 10, 2024
Grade: K-12
Cost: \$35.00 per participant

Clovis Community Sports and Recreation Department
Hustling Eagles Fall AAU Boys Basketball
Clovis West High School
Date: September 3 - October 31, 2024
Grade: 2-12
Cost: \$150.00 per participant

Clovis Community Sports and Recreation Department
Blue Line Boys Basketball Fall AAU
Clovis High School
Date: September 4 - October 9, 2024
Grade: 3-8
Cost: \$185.00 per participant

Clovis Community Sports and Recreation Department
Pre-Season Wrestling Training
Clovis High School
Date: September 9 - October 11, 2024
Grade: 7-12
Cost: \$0

Clovis Community Sports and Recreation Department
Free Elementary Baseball Camp
Clovis High School
Date: September 14, 2024
Grade: 1-6
Cost: \$0

Clovis Community Sports and Recreation Department
Boys Basketball JV Tournament
Clovis West High School
Date: September 14 - 15, 2024
Grade: 3-10
Cost: \$175.00 per team

Clovis Community Sports and Recreation Department
Boys Basketball Varsity Tournament
Clovis West High School
Date: September 14 - 15, 2024
Grade: 9-12
Cost: \$300.00 per team

Clovis Community Sports and Recreation Department
Lil Hoopsters Boys Basketball
Clovis High School
Date: January 11 - February 8, 2025
Grade: K-4
Cost: \$60.00 per participant

Clovis Community Sports and Recreation Department
Free Tryout Pep Clinic
Clovis North High School
Date: March 1 - 31, 2025
Grade: 7-11
Cost: \$0

Clovis Community Sports and Recreation Department
Elite Pack Wrestling Program
Clovis East High School
Date: March 3 - August 18, 2025
Grade: 7-8
Cost: \$150.00 per participant

Clovis Community Sports and Recreation Department
Blue Line Basketball Spring AAU
Clovis High School
Date: March 17 - May 14, 2025
Grade: 3-8
Cost: \$185.00 per participant

Clovis Community Sports and Recreation Department
Blue Line Basketball Spring and Summer High School Program
Clovis High School
Date: March 17 - July 18, 2025
Grade: 9-12
Cost: \$185.00 per participant

FISCAL IMPACT:

No fiscal impact.

REVISIONS:

ATTACHMENTS:

Description

Upload Date

CUSD Board Agenda Item

Agenda Item: N 5

Title: August 7, 2024, Governing Board Meeting Minutes

CONTACT: None

FOR INFORMATION: August 28, 2024

FOR ACTION: August 28, 2024

RECOMMENDATION:

Approve the minutes of the August 7, 2024, Governing Board meeting, as submitted.

DISCUSSION:

FISCAL IMPACT:

REVISIONS:

ATTACHMENTS:

Description

Upload Date

[8.7.2024_Minutes.pdf](#)

11-07-2024



GOVERNING BOARD MEETING

MINUTES

August 7, 2024

***Clovis North Educational Center Lecture Hall
2770 East International Avenue, Fresno, CA 93730***

5:30 P.M. – CLOSED SESSION

6:30 P.M. – PUBLIC SESSION

Members of the public who wish to provide public comments must do so in-person during the board meeting. **Please complete and submit a Public Comment Form before the start of the Public Session on the day of the meeting.** The Public Comment Form is available outside the board meeting room on the day of the meeting. During the meeting, speakers who have requested to address the Board will be called to do so. Comments on items that are on the agenda are to be made when the item is called by the Board President. Comments on matters that are not on the agenda are to be made during the Public Presentations. Pursuant to Board Bylaw No. 9323, each speaker generally has up to 2 minutes to speak. The Board President may adjust the time allotted for each speaker and limit the total time for public comment. No speaker may yield his or her time to another speaker.

Regular Meeting AGENDA

Additional information regarding this agenda may be viewed through the District's website at <https://www.cusd.com/BoardMeetingsAgendasArchives.aspx>

In compliance with the Americans with Disabilities Act, if you need special assistance to access the Board meeting room or to otherwise participate at this meeting, including auxiliary aids or services, please contact the Superintendent's Office at 327-9100. Notification at least 48 hours prior to the meeting will enable the District to make reasonable arrangements to ensure accessibility to the Board meeting.

Public records relating to an open session agenda item of a regular meeting that are distributed within 72 hours prior to the meeting will be available for public inspection at the District Office, 1450 Herndon Avenue, Clovis, California.

An invocation may be held prior to the start of the Board meeting. Attendance during and participation in the invocation are optional and voluntary. No students, parents, members of the public, Board members, student board member, or employees are required to attend or participate in the invocation.

INVOCATION

Board Member Steven Fogg, M.D. led the invocation.

A. CALL TO ORDER

President Hugh Awtrey called the Governing Board meeting to order at 5:30 p.m.

B. ROLL CALL

Board Members Present:

Hugh Awtrey, President
Yolanda Moore, Vice President
Clinton Olivier, Clerk
Deena Combs-Flores, Member
David DeFrank, Member
Steven Fogg, M.D., Member
Tiffany Stoker Madsen, Member

District Administration Present:

Corrine Folmer, Ed.D., Superintendent
Norm Anderson, Deputy Superintendent
Marc Hammack, Ed.D., Associate Superintendent
Barry Jager, Associate Superintendent
Michael Johnston, Associate Superintendent
Shawn VanWagenen, General Counsel
Maiya Yang, General Counsel
Kelly Avants, APR, Chief Communications Officer

C. ADOPTION OF AGENDA

Adopted the August 7, 2024, Governing Board meeting agenda, as submitted.

Motion: Approve, Moved By Board Member Steven Fogg, Seconded by Board Member Clinton Olivier. Passed. 7-0. Board Members voting Ayes: Awtrey, Combs-Flores, DeFrank, Fogg, Moore, Olivier, Stoker Madsen

D. CLOSED SESSION

The Board adjourned to Closed Session at 5:31 p.m. to discuss the following items:

1. CONFERENCE WITH LEGAL COUNSEL – ANTICIPATED LITIGATION – Significant Exposure to Litigation (Pursuant to Subdivision (d)(2) of Gov't. Code §54956.9) – 1 case
2. CONFERENCE WITH LEGAL COUNSEL – EXISTING LITIGATION (Gov't Code §54956.9(d)) - SA-CE-3040-E, SA-CE-3047-E, SA-CE-3051-E
3. CONFERENCE WITH LABOR NEGOTIATORS (Education Code §54957.6) Agency Negotiator – Corrine Folmer, Ed.D., Supt. Negotiating Parties – Contracted Emps., Cert. Mgmt., Cert. Teachers, Class. Emps., Class. Mgmt. and Ops. Unit (Represented by CSEA Clovis Chapter 250)
4. APPOINTMENT/EMPLOYMENT OF INDIVIDUALS IN POSITIONS LISTED IN BOARD POLICY EXHIBITS NO. 4151.10, 4251.10, 4351.10, 4151.21, 4151.22, 4151.23, AND 4251.10 (Gov't. Code §54957)
5. PUBLIC EMPLOYEE DISCIPLINE/DISMISSAL/RELEASE/SUSPENSION (Gov't. Code §54957)
6. STUDENT DISCIPLINE AND OTHER CONFIDENTIAL STUDENT MATTERS (Education Code §48900 et seq. and §35146)

E. RECONVENE FOR PUBLIC SESSION

President Hugh Awtrey reconvened the public meeting at 6:30 p.m.

F. RECOGNITION OF VISITORS

President Hugh Awtrey welcomed meeting attendees present.

G. PLEDGE OF ALLEGIANCE

President Hugh Awtrey led the Board members and meeting attendees in the Pledge of Allegiance.

H. CLOSED SESSION MOTIONS

Approved routine Personnel Matters, as submitted.

Motion: Approve, Moved By Board Member Steven Fogg, Seconded by Board Member Clinton Olivier. Passed. 7-0. Board Members voting Ayes: Awtrey, Combs-Flores, DeFrank, Fogg, Moore, Olivier, Stoker Madsen.

I. SUPERINTENDENT'S REPORT

Superintendent Corrine Folmer, Ed.D. shared her report with the members of the Governing Board regarding recent news, events and achievements from across the District.

J. PUBLIC PRESENTATIONS

This time is reserved for individuals who may wish to address the Board regarding a matter that is not included on the agenda. Please note that because the items brought up by the public during this time are not on the agenda, the Governing Board may not discuss or act upon such items.

K. PUBLIC HEARINGS

1. Public Hearing Regarding the Conveyance of Public Utility Easement to Pacific Gas and Electric Company, APN 574-130-01T

Conducted a public hearing at 6:45 p.m. at 2770 East International Avenue, Fresno, 93730, regarding the conveyance of a public utility easement to Pacific Gas and Electric Company, APN 574-130-01T. No meeting attendees requested to speak at this public hearing.

L. CONSENT

1. Conference Requests

Approved the Conference Requests, as submitted.

Motion: Approve, Moved By Board Member Steven Fogg, Seconded by Board Member Clinton Olivier. Passed. 7-0. Board Members voting Ayes: Awtrey, Combs-Flores, DeFrank, Fogg, Moore, Olivier, Stoker Madsen.

2. Fundraiser Requests

Approved the Fundraiser Requests, as submitted.

Motion: Approve, Moved By Board Member Steven Fogg, Seconded by Board Member Clinton Olivier. Passed. 7-0. Board Members voting Ayes: Awtrey, Combs-Flores, DeFrank, Fogg, Moore, Olivier, Stoker Madsen.

3. Student Trip Requests

Approved the Student Trip Requests, as submitted.

Motion: Approve, Moved By Board Member Steven Fogg, Seconded by Board Member Clinton Olivier. Passed. 7-0. Board Members voting Ayes: Awtrey, Combs-Flores, DeFrank, Fogg, Moore, Olivier, Stoker Madsen.

4. Voluntary Community Recreation Programs

Approved the Voluntary Community Recreation Programs, as submitted.

Motion: Approve, Moved By Board Member Steven Fogg, Seconded by Board Member Clinton Olivier. Passed. 7-0. Board Members voting Ayes: Awtrey, Combs-Flores, DeFrank, Fogg, Moore, Olivier, Stoker Madsen.

5. July 17, 2024, Governing Board Meeting Minutes

Approved the minutes of the July 17, 2024, Governing Board meeting, as submitted.

Motion: Approve, Moved By Board Member Steven Fogg, Seconded by Board Member Clinton Olivier. Passed. 7-0. Board Members voting Ayes: Awtrey, Combs-Flores, DeFrank, Fogg, Moore, Olivier, Stoker Madsen.

6. Ratification of Purchase Orders, District Contracts and Check Register

Ratified Purchase Orders, District Contracts, and Warrants numbered 678078 through 678853.

Motion: Approve, Moved By Board Member Steven Fogg, Seconded by Board Member Clinton Olivier. Passed. 7-0. Board Members voting Ayes: Awtrey, Combs-Flores, DeFrank, Fogg, Moore, Olivier, Stoker Madsen.

7. Change Orders

Approved the Change Orders, as submitted.

Motion: Approve, Moved By Board Member Steven Fogg, Seconded by Board Member Clinton Olivier. Passed. 7-0. Board Members voting Ayes: Awtrey, Combs-Flores, DeFrank, Fogg, Moore, Olivier, Stoker Madsen.

8. Annual Agreements for Students with Special Needs Placed in Non-Public Schools

Authorized Clovis Unified School District to continue agreements with four non-public schools to address the unique educational needs of District students with special needs.

Motion: Approve, Moved By Board Member Steven Fogg, Seconded by Board Member Clinton Olivier. Passed. 7-0. Board Members voting Ayes: Awtrey, Combs-Flores, DeFrank, Fogg, Moore, Olivier, Stoker Madsen.

9. Annual Agreement for Student with Special Needs Placed in a Residential Treatment Center

Authorized Clovis Unified School District to continue the agreement with a residential treatment center to address the unique educational needs of a District student with special needs.

Motion: Approve, Moved By Board Member Steven Fogg, Seconded by Board Member Clinton Olivier. Passed. 7-0. Board Members voting Ayes: Awtrey, Combs-Flores, DeFrank, Fogg, Moore, Olivier, Stoker Madsen.

M. ACTION

In general (unless otherwise noted), these items were seen for Information at the prior Board meeting and will be voted on at this meeting. Agenda items titled "Annual" are recurring items submitted to the Board for approval yearly.

1. Agreement with ParentSquare, Inc.

Approved a three-year agreement with ParentSquare, Inc. for the provision of an integrated two-way communication platform for use at District schools and departments, as submitted.

Motion: Approve, Moved By Board Member Steven Fogg, Seconded by Board Member Clinton Olivier. Passed. 7-0. Board Members voting Ayes: Awtrey, Combs-Flores, DeFrank, Fogg, Moore, Olivier, Stoker Madsen.

2. Clovis Adult Education Courses 2024-25

Approved the Clovis Adult Education course offerings for the 2024-25 school year, as submitted.

Motion: Approve, Moved By Board Member Clinton Olivier, Seconded by Board Member Yolanda Moore. Passed. 7-0. Board Members voting Ayes: Awtrey, Combs-Flores, DeFrank, Fogg, Moore, Olivier, Stoker Madsen.

3. Resolution No. 3998 – Annual Authorization of Inter-Fund Loans for Cash Flow Purposes
Adopted Resolution No. 3998 authorizing inter-fund loans for cash flow purposes, as submitted.

Motion: Approve, Moved By Board Member Steven Fogg, Seconded by Board Member Clinton Olivier. Passed. 7-0. Board Members voting Ayes: Awtrey, Combs-Flores, DeFrank, Fogg, Moore, Olivier, Stoker Madsen.

4. Resolution No. 4000 - Approving Conveyance of Public Utility Easement to Pacific Gas and Electric Company, APN 574-130-01T

Adopted Resolution No. 4000 approving the conveyance of a public utility easement to Pacific Gas and Electric Company, regarding APN 574-130-01T (TWO-THIRDS VOTE REQUIRED). A roll call vote was held for this agenda item.

Motion: Approve, Moved By Board Member Steven Fogg, Seconded by Board Member Clinton Olivier. Passed. 7-0. Board Members voting Ayes: Awtrey, Combs-Flores, DeFrank, Fogg, Moore, Olivier, Stoker Madsen.

5. Resolution No. 4002 - Declaring Intention to Convey Easement to Fresno Metropolitan Flood Control District and Setting of Public Hearing, APNs 310-320-03ST, 310-320-05ST, 310-320-06ST, 310-050-38T

Adopted Resolution No. 4002 declaring the intention to convey an easement to Fresno Metropolitan Flood Control District (FMFCD) and set a public hearing for installation of a storm drain and other incidental purposes, APNs 310-320-03ST, 310-320-05ST, 310-320-06ST, 310-050-38T (TWO-THIRDS VOTE REQUIRED).

Motion: Approve, Moved By Board Member Steven Fogg, Seconded by Board Member Clinton Olivier. Passed. 7-0. Board Members voting Ayes: Awtrey, Combs-Flores, DeFrank, Fogg, Moore, Olivier, Stoker Madsen.

N. INFORMATION

Unless otherwise noted, these items are on the agenda to provide time for Board members to review prior to taking action on the items at the next Board meeting. Agenda items titled "Annual" are recurring items submitted to the Board for approval yearly.

1. Provisional Internship Permit
Approve the Provisional Internship Permit for the recommended teaching candidate, as submitted.
2. Section 125 Amendment to Flexible Benefit Plan
Approve an amendment to the District's Section 125 Flexible Benefit Plan, as submitted.
3. Triennial Agreement with CommonLit
Authorize the Superintendent or designee to enter into an agreement with CommonLit, a web-based toolkit, effective for a three-year period for school years 2024-25, 2025-26, and 2026-27.
4. Action Mentoring Program Agreement for 2024-25
Approve the mentoring agreement with Action Mentoring Program (AMP), as submitted.
5. Annual California School Boards Association Membership and Education Legal Alliance
Should the Governing Board desire to maintain its membership in the California School Boards Association (CSBA) for the 2024-25 school year, it will be necessary for the Board to approve

the payment of dues in the amount of \$26,289. For membership in the Education Legal Alliance (ELA), the Board will need to approve the payment in the amount of \$6,572.

6. Resolution No. 4003 - Approving Conveyance of Easement to Fresno Metropolitan Flood Control District, APNs 310-320-03ST, 310-320-05ST, 310-320-06ST, 310-050-38T
Adopt Resolution No. 4003 approving the conveyance of an easement to Fresno Metropolitan Flood Control District (FMFCD) for installation of a storm drain and other incidental purposes regarding APNs 310-320-03ST, 310-320-05ST, 310-320-06ST, 310-050-38T (TWO-THIRDS VOTE REQUIRED).
7. Resolution No. 4004 - Exemption to the Separation-from-Service Requirement for One Certificated Retiree
Adopt Resolution No. 4004, approving an exemption to the separation-from-service requirement for the 2024-25 school year (Education Code § 24214.5 or 26812).
8. Resolutions No. 4005 and 4006 – Exemptions to the Separation-from-Service Requirement for Two Classified Retirees
Adopt Resolutions No. 4005 and 4006 authorizing Clovis Unified School District to hire two CalPERS retirees prior to the 180-day post-retirement waiting period.
9. Award of Bid - Services
Recommendation for RFP 2998 - Charter Bus Services will be brought to the Governing Board for Action at a future date.

O. BOARD MEMBER REPORTS

P. ADJOURNMENT

President Hugh Awtrey adjourned the Governing Board meeting at 6:58 p.m.

RESPECTFULLY SUBMITTED:

Clerk

Secretary

CUSD Board Agenda Item

Agenda Item: N 6

Title: Ratification of Purchase Orders, District Contracts and Check Register

CONTACT: Michael Johnston

FOR INFORMATION:

FOR ACTION:

RECOMMENDATION:

Ratify Purchase Orders, District Contracts, and Warrants numbered 679840 through 680627.

DISCUSSION:

District Administration recommends ratification of the Purchase Orders and District Contracts for the period of July 22, 2024-August 13, 2024, as well as the Warrant register for July 25, 2024-August 12, 2024. This information is available for review in the Purchasing and Accounting departments. Questions may be directed to the Business Services Department at 559-327-9127.

FISCAL IMPACT:

REVISIONS:

ATTACHMENTS:

Description

Upload Date

CUSD Board Agenda Item

Agenda Item: N 7

Title: Change Orders

CONTACT: Michael Johnston

FOR INFORMATION:

FOR ACTION:

RECOMMENDATION:

Approve the Change Orders, as submitted.

DISCUSSION:

Change Order Number	Contract/ Bid Number	Project Type	Site(s)	DSA Number
CHET-06 04	Bid 2960	Modernization - 2023	Cark Intermediate School MET Modernization - Phase 2	02-121097
CE-07 10	Bid 2922	New Construction - 2023	Hrayena Elementary School - Phase 1 and 2	02-120543
CE-11 01	Bid 2922	New Construction - 2023	Hrayena Elementary School - Phase 1 and 2	02-120543
CE-12 06	Bid 2922	New Construction - 2023	Hrayena Elementary School - Phase 1 and 2	02-120543
CE-16 05	Bid 2922	New Construction - 2023	Hrayena Elementary School - Phase 1 and 2	02-120543
DD-04 02	Bid 2965	New Construction - 2024	District Campus - Phase 1	02-121813
02	Bid 29102912-31A	New Construction - 2024	Terry Bradley Educational Center - Phase 31A	02-120345
04	Bid 29642971-20A	New Construction - 2023	Terry Bradley Educational Center - Phase 20A	02-120345
09	Bid 2901-18	New Construction - 2022	Terry Bradley Educational Center - Phase 18	NA

FISCAL IMPACT:

As noted in the attachment.

REVISIONS:

ATTACHMENTS:

Description

[Change_Orders-2-.pdf](#)

Upload Date

12-16-2024

Contract Change Order No. 04

Project Clark MET Mod. Phase 2 (2023) **Date** 8/28/2024
 20012
Bid No./Contract Bid No. 2960 /CMET-06
 (3240242)

Description CMET-06-CO4

From Clovis Unified School District
 1470 Herndon Avenue
 Clovis, CA 93611 **To** Ardent General Inc.
 2960 N. Burl Ave.
 Fresno, California 93727

Item No.	Item Description	Item Amount	Reason for Change
01	Added casework in arts classroom.	\$65,508.00	District Change

Description: Added casework in arts classroom.
 Requested By: District Change. \$65,508.00 to be added to the contract.
 Reason for Change: District Change. The casework in the arts classroom will be replaced with new custom casework to meet District Standards.

Item No.	Item Description	Item Amount	Reason for Change
02	Added access ladder.	\$1,731.60	A&E Omission

Description: Added access ladder.
 Requested By: A&E Omission. \$1,731.60 to be added to the contract.
 Reason for Change: A&E Omission. There was no access to door 205B in room 205. An access ladder was added to reach the door which is +/-13' above the finish floor.

Item No.	Item Description	Item Amount	Reason for Change
03	Modify coiling door.	\$3,154.34	District Change

Description: Modify coiling door.
 Requested By: District Change. \$3,154.34 to be added to the contract.
 Reason for Change: District Change. The cased opening frame for coiling door 206e was modified due to the coiling door increasing from 8' in height to 10'. The increase in door height was needed to move larger equipment in from the existing MET to the new workshop area.

Total for this Current CCO \$70,393.94

CONTRACT SUMMARY:

Original Contract	\$1,439,500.00
Pending CCOs (Including Current CCO)	\$80,909.14
Previous Approved CCOs	\$22,029.30
Total Contract	\$1,542,438.44

The revised contract amount is an increase of 7.15% from the original amount.

Contract Change Order No. 10

Project Hirayama Elem. Sch. Phase 1 & 2 (2023) 35060 (Fowler McKinley) **Date** 8/28/2024
Bid No./Contract Bid No. 2922 /CES-07 (3240064) Bid 2923 (Phase 2)

Description CES-07-CO10

From Clovis Unified School District
 1470 Herndon Avenue
 Clovis, CA 93611 **To** DAC Service Inc., dba Four C's Construction
 1560 H Street
 Fresno, California 93721

Item No.	Item Description	Item Amount	Reason for Change
01	Revised attachment conditions at metal soffit rake.	\$28,468.00	A&E Omission

Description: Revised attachment conditions at metal soffit rake.
 Requested By: A&E Omission. \$28,468.00 to be added to the contract.
 Reason for Change: A&E Omission. The metal soffit panels are 12" wide and run parallel with framing at rake conditions. The soffit framing schedule indicates metal stud spacing at 2'-0" on center. In order to achieve adequate attachment at rake conditions with a 12" wide metal panel, a 16 gauge 4" wide flat strap at 2'-0" on center will be installed.

Total for this Current CCO \$28,468.00

CONTRACT SUMMARY:

Original Contract	\$3,656,900.00
Pending CCOs (Including Current CCO)	\$48,886.00
Previous Approved CCOs	\$73,192.00
Total Contract	\$3,778,978.00

The revised contract amount is an increase of 3.34% from the original amount.

Contract Change Order No. 01

Project Hiramama Elem. Sch. Phase 1 & **Date** 8/28/2024
 2 (2023) 35060 (Fowler
 McKinley)
Bid No./Contract Bid No. 2922 /CES-11
 (3240024) Bid 2923 (Phase 2)

Description CES-11-CO1

From Clovis Unified School District **To** Ro's Precise Painting
 1470 Herndon Avenue 1816 Industrial Way
 Clovis, CA 93611 Sanger, California 93657

Item No.	Item Description	Item Amount	Reason for Change
01	Overtime for May.	\$8,873.00	Unforeseen Condition

Description: Overtime for May.
 Requested By: Unforeseen Condition. \$8,873.00 to be added to the contract.
 Reason for Change: Unforeseen Condition. Due to delays caused by The Division of the State Architect, overtime for polishing concrete floors was required to maintain the project completion date.

Total for this Current CCO \$8,873.00

CONTRACT SUMMARY:

Original Contract	\$461,953.00
Pending CCOs (Including Current CCO)	\$8,873.00
Previous Approved CCOs	\$0.00
Total Contract	\$470,826.00

The revised contract amount is an increase of 1.92% from the original amount.

Contract Change Order No. 06

Project Hirayama Elem. Sch. Phase 1 & 2 (2023) 35060 (Fowler McKinley) **Date** 8/28/2024
Bid No./Contract Bid No. 2922 /CES-12 (3230822) Bid 2923 (Phase 2)

Description CES-12-CO6

From Clovis Unified School District
 1470 Herndon Avenue
 Clovis, CA 93611 **To** Better Enterprises, Inc.
 1148 N Cypress Ave
 Fresno, California 93727

Item No.	Item Description	Item Amount	Reason for Change
01	Interim housing added signage.	\$4,740.00	Unforeseen Condition

Description: Interim housing added signage.
 Requested By: Unforeseen Condition. \$4,740.00 to be added to the contract.
 Reason for Change: Unforeseen Condition. Due to delays caused by the Division of the State Architect, temporary modular buildings will be utilized as classrooms for the beginning of the school year. These required additional signage for room numbering and bathroom designations.

Item No.	Item Description	Item Amount	Reason for Change
02	Added seismic restraints for equipment.	\$8,895.00	Agency Requirement

Description: Added seismic restraints for equipment.
 Requested By: Agency Requirement. \$8,895.00 to be added to the contract.
 Reason for Change: Agency Requirement. The Division of the State Architect required seismic restraints at all food service equipment.

Total for this Current CCO \$13,635.00

CONTRACT SUMMARY:

Original Contract	\$5,473,071.00
Pending CCOs (Including Current CCO)	\$6,494.00
Previous Approved CCOs	\$(33,209.81)
Total Contract	\$5,446,355.19

The revised contract amount is a decrease of .05% from the original amount.

Contract Change Order No. 05

Project Hirayama Elem. Sch. Phase 1 & 2 (2023) 35060 (Fowler McKinley) **Date** 8/28/2024
Bid No./Contract Bid No. 2922 /CES-16 (3230820) Bid 2923 (Phase 2)

Description CES-16-CO5

From Clovis Unified School District
 1470 Herndon Avenue
 Clovis, CA 93611 **To** Avison Construction, Inc.
 40434 Brickyard Drive
 Madera, California 93636

Item No.	Item Description	Item Amount	Reason for Change
01	Added water meter boxes.	\$2,300.00	Agency Requirement

Description: Added water meter boxes.
 Requested By: Agency Requirement. \$2,300.00 to be added to the contract.
 Reason for Change: Agency Requirement. The City of Fresno required 4" and 6" meter boxes to be installed for offsite improvements. Soil had to be removed and the boxes were set.

Total for this Current CCO \$2,300.00

CONTRACT SUMMARY:

Original Contract	\$3,997,483.00
Pending CCOs (Including Current CCO)	\$96,177.00
Previous Approved CCOs	\$601,418.00
Total Contract	\$4,695,078.00

The revised contract amount is an increase of 17.45% from the original amount.

Contract Change Order No. 02

Project District Campus Ph. 1 (2023) **Date** 8/28/2024
 37046
Bid No./Contract Bid No. 2965 /DOE-04
 (3240404)

Description OL: Steel saddles

From Clovis Unified School District **To** Fresno Fab-tech, Inc
 1470 Herndon Avenue 1035 K Street
 Clovis, CA 93611 Sanger, California 93657

Item No.	Item Description	Item Amount	Reason for Change
01	OL: Steel saddles.	\$1,130.00	A&E Omission

Description: OL: Steel saddles.
 Requested By: A&E Omission. \$1,130.00 to be added to the contract.
 Reason for Change: A&E Omission. Fabrication and install of three steel saddles was required to complete wood framing.

Total for this Current CCO \$1,130.00

CONTRACT SUMMARY:

Original Contract	\$1,199,500.00
Pending CCOs (Including Current CCO)	\$1,130.00
Previous Approved CCOs	\$0.00
Total Contract	\$1,200,630.00

The revised contract amount is an increase of 0.09% from the original amount.

Contract Change Order No. 02

Project TBEC (2023) 20004-3 and 3A **Date** 8/28/2024
Bid No./Contract Bid No. 2970-3 / 2972-3A
/3240611

Description Terry Bradley Educational Center Increment 3 - Site Work

From Clovis Unified School District **To** Harris Construction Company, Inc.
1470 Herndon Avenue 5286 E. Home Ave.
Clovis, CA 93611 Fresno, California 93727

Item No.	Item Description	Item Amount	Reason for Change
01	Ice Maker modification.	\$0.00	District Change

Description: Ice Maker modification.
Requested By: District Change. \$0.00 on this change order. \$4,768.00 from Lease - Lease Back contingency.
Reason for Change: District Change. The District requested the Prodigy Elite Ice Maker with bin in lieu of the specified Manitowac model.

Item No.	Item Description	Item Amount	Reason for Change
02	Modifications to site utilities at Buildings A, F, and J.	\$0.00	A&E Omission

Description: Modifications to site utilities at Buildings A, F, and J.
Requested By: A&E Omission. \$0.00 on this change order. \$49,187.00 from Lease - Lease Back contingency.
Reason for Change: A&E Omission. Utility modifications were made to sewer, storm drain, domestic water and fire water piping at Buildings A, F, and J.

Total for this Current CCO \$0.00

CONTRACT SUMMARY:

Original Contract	\$72,506,817.00
Pending CCOs (Including Current CCO)	\$0.00
Previous Approved CCOs	\$0.00
Total Contract	\$72,506,817.00

No price change from the original contract amount.

Contract Change Order No. 04

Project TBEC (2023) 20004-2 and 2A **Date** 8/28/2024
Bid No./Contract Bid No. 2964-2 / 2971-2A /LLB
 (3240441) Bid 2964-2 and
 2971-2A

Description Terry Bradley Educational Center Increment 2 - Site Work

From Clovis Unified School District **To** Harris Construction Company, Inc.
 1470 Herndon Avenue 5286 E. Home Ave.
 Clovis, CA 93611 Fresno, California 93727

Item No.	Item Description	Item Amount	Reason for Change
01	Provide fire utility and hydrant modifications.	\$0.00	Agency Requirement

Description: Provide fire utility and hydrant modifications.
 Requested By: Agency Requirement. \$0.00 on this change order. \$238,252.00 from Lease - Lease Back contingency.
 Reason for Change: Agency Requirement. Modifications to the fire water piping and Post Indicator Valve and Fire Department connection locations that were required by Fresno Fire Department.

Total for this Current CCO \$0.00

CONTRACT SUMMARY:

Original Contract	\$80,724,724.00
Pending CCOs (Including Current CCO)	\$0.00
Previous Approved CCOs	\$0.00
Total Contract	\$80,724,724.00

No price change from the original contract amount.

Contract Change Order No. 09

Project TBEC (2022) 20004-1B **Date** 8/28/2024
Bid No./Contract Bid No. 2921-1B /LLB (3230554)
 Bid 2921-1B

Description Terry Bradley Educational Center Increment 1B - Site Work

From Clovis Unified School District
 1470 Herndon Avenue
 Clovis, CA 93611 **To** Harris Construction Company, Inc.
 5286 E. Home Ave.
 Fresno, California 93727

Item No.	Item Description	Item Amount	Reason for Change
01	Credit for modifications to concrete masonry unit Utility Yards.	\$0.00	A&E Omission

Description: Credit for modifications to concrete masonry unit Utility Yards.
 Requested By: A&E Omission. \$(142,233.00) on this change order. (\$142,233.00) credited back to Lease - Lease Back contingency.
 Reason for Change: A&E Omission. Modifications resulting in a credit to the project include omitting utility yards, modifying the sizes of the remaining utility yards, and modifying the concrete masonry unit wall patterns.

Item No.	Item Description	Item Amount	Reason for Change
02	Fresno Irrigation District easement utility crossing.	\$0.00	Agency Requirement

Description: Fresno Irrigation District easement utility crossing.
 Requested By: Agency Requirement. \$20,065.00 on this change order. \$20,065.00 from Lease - Lease Back contingency.
 Reason for Change: Agency Requirement. Fresno Irrigation District (FID) required the already installed electrical conduit be relocated outside of FID easement and reinstalled per agency standards.

Item No.	Item Description	Item Amount	Reason for Change
03	Provide additional conduit and trenching to the future lift station at the on-site utility yard.	\$0.00	Agency Requirement

Description: Provide additional conduit and trenching to the future lift station at the on-site utility yard.
 Requested By: Agency Requirement. \$0.00 on this change order. \$56,609.00 from Lease - Lease Back contingency.
 Reason for Change: Agency Requirement. Conduit from yard #7 was required to power the future lift station.

Item No.	Item Description	Item Amount	Reason for Change
04	Dewatering the site at Building F and Parking Lot A.	\$0.00	Unforeseen Condition

Description: Dewatering the site at Building F and Parking Lot A.
 Requested By: Unforeseen Condition. \$0.00 on this change order. \$1,787.00 from Lease - Lease Back contingency.
 Reason for Change: Unforeseen Condition. Additional dewatering was required due to heavy rainfall and the need to maintain the current construction schedule.

Item No.	Item Description	Item Amount	Reason for Change
05	Relocate the PG&E gas meter.	\$0.00	Agency Requirement

Description: Relocate the PG&E gas meter.
 Requested By: Agency Requirement. \$0.00 on this change order. \$8,424.00 from Lease - Lease Back contingency.
 Reason for Change: Agency Requirement. PG&E required the already installed gas meter be relocated from inside of Yard #1 to the outside of the yard for PG&E access.

Item No.	Item Description	Item Amount	Reason for Change
06	Provide additional rebar at light pole anchor bolts at the tennis courts.	\$0.00	A&E Omission

Description: Provide additional rebar at light pole anchor bolts at the tennis courts.
 Requested By: A&E Omission. \$0.00 on this change order. \$922.00 from Lease - Lease Back contingency.
 Reason for Change: A&E Omission. Additional rebar was required to support the light pole base anchor bolts to allow the mow strip to run continuously over the top of the light pole base.

Total for this Current CCO \$0.00

CONTRACT SUMMARY:

Original Contract	\$41,195,468.00
Pending CCOs (Including Current CCO)	\$0.00
Previous Approved CCOs	\$0.00
Total Contract	\$41,195,468.00

No price change from the original contract amount.

CUSD Board Agenda Item

Agenda Item: N 8

Title: Approval of Early Admission to Kindergarten

CONTACT: Marc Hammack

FOR INFORMATION: August 28, 2024

FOR ACTION: August 28, 2024

RECOMMENDATION:

Approve early admission to Kindergarten and determine that admittance is in the best interest of the child.

DISCUSSION:

Pursuant to Education Code Section 48000 and Board Policy 5111, parents of a student requested early admission to Kindergarten and provided compelling evidence that the student was prepared to enter Kindergarten. Staff has conducted an evaluation of the student's academic, social and physical readiness, and prepared written support for early admission that has been provided to the Board for consideration.

FISCAL IMPACT:

REVISIONS:

ATTACHMENTS:

Description

Upload Date

CUSD Board Agenda Item

Agenda Item: O 1

Title: Extraterritorial Water, Sewer and Related Services and Offsite Infrastructure Agreement Between Clovis Unified School District and the City of Fresno

CONTACT: Michael Johnston

FOR INFORMATION: August 14, 2024

FOR ACTION: August 28, 2024

RECOMMENDATION:

Approve the Extraterritorial Water, Sewer, and Related Services and Offsite Infrastructure Agreement (Agreement) between Clovis Unified School District and the City of Fresno relating to the Terry P. Bradley Educational Center, and authorize the Superintendent or designee to make such changes thereto as may be necessary or proper to finalize and execute the agreement with the City of Fresno.

DISCUSSION:

This Agreement relates to the Terry P. Bradley Educational Center site located at 2501 N. Highland Avenue. At the time of its development, this school site was located within the City of Fresno's sphere of influence, but outside of the City of Fresno's municipal limits. The Agreement provides for the City of Fresno to extend its water, sewer, and related services outside of the City limits and to the school site and for the construction of related infrastructure, according to the terms and considerations outlined in the Agreement.

FISCAL IMPACT:

REVISIONS:

ATTACHMENTS:

Description

Upload Date

Title: Provisional Internship Permit

CONTACT: Barry Jager

FOR INFORMATION: August 14, 2024

FOR ACTION: August 28, 2024

RECOMMENDATION:

Approve the Provisional Internship Permit (PIP) for the recommended teaching candidates, as submitted.

DISCUSSION:

The PIP is available when the employing agency knows that there will be a teacher vacancy yet is unable to recruit a suitable candidate. The expectations of the employer and the employee are higher since this individual will be the teacher of record and should be on a credential track. The focus of the document is meeting subject matter competency. Once a candidate completes subject matter competency, the candidate can be employed on a document such as a District Internship Credential. Candidate requirements include the following: (1) Bachelor’s degree or higher; (2) passage of the California Basic Educational Skills Test (CBEST); and (3) specific course work or experience, explained in detail on the PIP information leaflet.

As required by the California Commission on Teacher Credentialing (CCTC), employing agencies offering employment to a candidate on a PIP are required to: (1) conduct a diligent search for a suitable credentialed teacher or qualified internship teacher; (2) provide the PIP holder with orientation, guidance, and assistance as specified in Title 5 Section 80026.5 of the California Code of Regulations; (3) assist the PIP holder in developing a personalized plan (kept on file at the local level) through an agency-defined assessment leading to completion of subject matter competence; and (4) counsel the PIP holder to enroll in subject matter training. Clovis Unified School District administration hereby declares that a diligent search was conducted for suitable credentialed teachers or qualified internship teachers. Upon Board approval, District administration asserts that steps 2-4, as outlined above, will be completed.

School districts submitting PIP requests must include verification that a notice of intent to employ the applicant in the identified position was made public. The public notice must include the following information: (1) the names of the applicants; (2) the assignments in which the applicants will be employed including subjects, grade levels, and school sites; and (3) a statement that the applicants will be employed on the basis of a PIP. Clovis Unified intends to submit a PIP request for the following teacher candidates, contingent upon administration and Board approval:

Name of Applicant	Assignment	Grade Level	School Site	Employment Status
Antonio Castillo	Resource Specialist	9-12	Clovis East High School	PIP (Education Specialist Mild to Moderate Support Needs)
Brianne Carter*	SDC, Functional Skills	K-6	Nelson Elementary School	PIP (Education Specialist Mild to Moderate Support Needs)

A PIP shall be issued for one year and may not be renewed.

Lastly, public school districts must include a copy of the agenda item presented to the Governing Board of the district. The agenda item must be presented in a public meeting as an action item and include the information above for each individual for whom the permit will be requested. The permit request must include a signed statement from the Superintendent, or designee, that the item was acted upon favorably. To assure that each permit request receives individual review and approval by the Governing Board, the agenda item may not be part of the consent agenda.

FISCAL IMPACT:

REVISIONS:

*This candidate's name has been added since the item originally went for information on August 7, 2024, and is submitted directly for action as the new school year has started.

ATTACHMENTS:

Description

Upload Date

Title: Section 125 Amendment to Flexible Benefit Plan

CONTACT: Michael Johnston

FOR INFORMATION: August 14, 2024

FOR ACTION: August 28, 2024

RECOMMENDATION:

Approve an amendment to the District's Section 125 Flexible Benefit Plan, as submitted.

DISCUSSION:

Clovis Unified has maintained a Flexible Benefit Plan since February 1994 in order to make a broader range of benefits available to its employees and their beneficiaries. This plan allows employees to choose among different types of benefits and select the combination best suited to their individual goals, desires and needs. These choices include an option to receive certain benefits in lieu of taxable compensation. The plan helps Clovis Unified attract, reward and retain highly qualified, skilled employees.

The change to the 2024-25 plan is as follows:

- The Flex Maximum will increase from \$3,050 to \$3,200.

The revised Section 125 Flexible Benefit Plan is available for review in the Administrative Services Department.

FISCAL IMPACT:

No fiscal impact.

REVISIONS:

ATTACHMENTS:

Description

Upload Date

Title: Triennial Agreement with CommonLit

CONTACT: Marc Hammack

FOR INFORMATION: August 7, 2024

FOR ACTION: August 28, 2024

RECOMMENDATION:

Authorize the Superintendent or designee to enter into an agreement with CommonLit, a webbased toolkit, effective for a three-year period for school years 2024-25, 2025-26, and 2026-27.

DISCUSSION:

CommonLit is a digital literacy program offering engaging reading lessons, benchmark assessments, and detailed standards-based data to help teachers track progress. CommonLit will be utilized as a supplemental material for intervention and to enhance our core curriculum. Students benefit from diverse and thought-provoking texts that promote critical thinking and analytical skills. These texts will also be utilized in Curriculum Design Teams to develop District common assessments. The program includes built-in scaffolds and accessibility tools, ensuring all students can access the material, regardless of their reading level. Teachers have access to high-quality, research-backed content and structured lessons designed to reach all learners. The digital platform also features built-in professional development resources, with partnerships providing virtual training sessions for teachers and school leaders throughout the year.

FISCAL IMPACT:

The fiscal impact for a contract with CommonLit is \$120,750 over three years, to be included in the Curriculum, Instruction and Accountability budget.

REVISIONS:

ATTACHMENTS:

Description

Upload Date

Title: Action Mentoring Program Agreement for 2024-25

CONTACT: Marc Hammack

FOR INFORMATION: August 7, 2024

FOR ACTION: August 28, 2024

RECOMMENDATION:

Approve the mentoring agreement with Action Mentoring Program (AMP), as submitted.

DISCUSSION:

AMP aims to support youth in bringing about positive youth development in students that have experienced or are experiencing adverse circumstances and provide mentorship and community resources to meet the needs of those students.

The overall goal and objective of AMP is to help foster a supportive learning environment and assist in facilitating the success of students' academic goals and the needs of the whole person. Through meaningful relationships and support, the mentorship program is structured to enhance student participation, increase engagement in learning, and cultivate student skills and confidence for future success.

AMP will provide mentoring services five days per week to all students enrolled in Clovis Community Day, Clovis Online and Gateway High schools. Mentors will strive to build relationships in a manner that assists in identifying each student's unique path for development. Additionally, mentors will introduce incentives that will aim to motivate and inspire students to actively engage in and complete tasks. The incentives are carefully designed to enhance participation, sustain interest, and cultivate excitement among students.

FISCAL IMPACT:

Total cost of agreement for 2024-25 school year is \$168,030, which will be funded through LCAP and Title I resources.

REVISIONS:

ATTACHMENTS:

Description

Upload Date

CUSD Board Agenda Item

Agenda Item: O 6

Title: Annual California School Boards Association Membership

CONTACT: Corrine Folmer

FOR INFORMATION: August 7, 2024

FOR ACTION: August 28, 2024

RECOMMENDATION:

Should the Governing Board desire to maintain its membership in the California School Boards Association (CSBA) for the 2024-25 school year, it will be necessary for the Board to approve the payment of dues in the amount of \$26,289.

DISCUSSION:

CSBA is a nonprofit education association representing the elected officials who govern public school districts and county offices of education. A membership-driven association, CSBA provides policy resources and training to members, and represents the statewide interests of public education through legal, political, legislative, community and media advocacy.

The 2024-25 CSBA membership dues are \$26,289 which an increase of \$2,917 from 2023-24.

FISCAL IMPACT:

Included in the 2024-25 budget, paid from the Governing Board budget.

REVISIONS:

CSBA and Education Legal Alliance memberships (action items O-6 and O-7) were originally submitted as one information agenda item and are now two separate action items.

ATTACHMENTS:

Description

Upload Date

CUSD Board Agenda Item

Agenda Item: O 7

Title: Annual Education Legal Alliance Membership

CONTACT: Corrine Folmer

FOR INFORMATION: August 7, 2024

FOR ACTION: August 28, 2024

RECOMMENDATION:

Should the Governing Board desire to obtain a membership in the Education Legal Alliance (ELA), it will be necessary for the Board to approve the payment of dues in the amount of \$6,572.

DISCUSSION:

The ELA is a consortium of over 700 dues-paying school districts, county offices of education, and regional occupational centers and programs (ROCPs) that have joined together to aid and defend the interests of those school districts, county offices of education, and ROCPs in California. The ELA is staffed by California School Boards Association's (CSBA) Legal Department.

The dues of \$6,572 are an increase of \$594 from 2023-24.

FISCAL IMPACT:

Included in the 2024-25 budget, paid from the Governing Board budget

REVISIONS:

CSBA and Education Legal Alliance memberships (action items O-6 and O-7) were originally submitted as one information agenda item and are now two separate action items.

ATTACHMENTS:

Description

Upload Date

CUSD Board Agenda Item

Agenda Item: O 8

Title: Resolution No. 4003 - Approving Conveyance of Easement to Fresno Metropolitan Flood Control District, APNs 310-320-03ST, 310-320-05ST, 310-320-06ST, 310-050-38T

CONTACT: Michael Johnston

FOR INFORMATION: August 7, 2024

FOR ACTION: August 28, 2024

RECOMMENDATION:

Adopt Resolution No. 4003 approving the conveyance of an easement to Fresno Metropolitan Flood Control District (FMFCD) for installation of a storm drain and other incidental purposes regarding APNs 310-320-03ST, 310-320-05ST, 310-320-06ST and 310-050-38T (TWO THIRDS VOTE REQUIRED).

DISCUSSION:

Clovis Unified School District ("District") owns the real property located at 2501 N. Highland Ave., Fresno, CA 93727, in the County of Fresno, and bearing Fresno County Assessor's Parcel Numbers 310-320-03ST, 310-320-05ST, 310-320-06ST, and 310-050-38T ("Property"). The District has undertaken a public works project to design and construct a new educational center including a high school and an intermediate school ("Project") on the Property. The first phase of the Project is anticipated to be completed by August 2025.

The purpose of the proposed easement is to grant FMFCD access to the Property to install, construct, operate, maintain, repair, remove and replace an underground storm drainage pipeline and to conduct water through the same, including a right of ingress thereto and egress therefrom. The proposed easement would prohibit the construction of any structures within the easement area, including buildings, roof overhangs and swimming pools.

The conveyance of the easement to FMFCD is authorized by the California Education Code. Pursuant to Education Code section 17556, a school district governing board may dedicate or convey to any public corporation or private corporation engaged in the public utility business an easement to lay, construct, reconstruct, maintain, and operate water, sewer, gas, or storm drain pipes or ditches, electric or telephone lines, and access roads used in connection therewith, over and upon any land belonging to the school district, upon such terms and conditions as agreed to by the parties. Education Code section 17577 requires the governing board, by not less than a two-thirds vote of all of its board members, to adopt a resolution declaring its intention to dedicate or convey the easement and set a public hearing not less than 10 days thereafter on the question of making the conveyance.

The dedication and conveyance of an easement pursuant to Education Code section 17556 et seq. is a two-step process. At the August 7, 2024, Board meeting, the Board adopted Resolution No. 4002 declaring its intention to convey the easement to FMFCD and set a public hearing for this Board meeting on August 28, 2024. Resolution No. 4002 was unanimously adopted.

The Board actions for the second step are anticipated to occur at this Board meeting on August 28, 2024. At this meeting, the Board will: (1) hold the public hearing on the question of making the conveyance of the easement to FMFCD; and (2) consider and adopt the proposed Resolution No. 4003, attached, to approve the conveyance of the easement to FMFCD.

FISCAL IMPACT:

No fiscal impact.

REVISIONS:

ATTACHMENTS:

Description

Upload Date

[Resolution_No._4003-1-.pdf](#)

12-19-2024

**RESOLUTION NO. 4003
BEFORE THE GOVERNING BOARD
OF THE CLOVIS UNIFIED SCHOOL DISTRICT
FRESNO COUNTY, CALIFORNIA**

**APPROVING CONVEYANCE OF EASEMENT
AND AUTHORIZING EXECUTION OF AGREEMENT
AND ACTIONS RELATED THERETO**

GRANTEE: FRESNO METROPOLITAN FLOOD CONTROL DISTRICT (FMFCD)

**PROPERTY: APNs 310-320-03ST, 310-320-05ST, 310-320-06ST, 310-050-38T
2501 N. HIGHLAND AVENUE, FRESNO, CALIFORNIA, 93727**

WHEREAS, Clovis Unified School District (“District”) owns the Property listed above and described in Exhibit A attached hereto.

WHEREAS, The District has undertaken a public works project to design and construct a new educational center including a high school and an intermediate school (“Project”) on the Property. A portion of the Project is anticipated to be completed by August 2025.

WHEREAS, the District desires to grant Fresno Metropolitan Flood Control District (FMFCD) a perpetual and exclusive easement in, through, over, and under the Property to install, construct, operate, maintain, repair, remove and replace an underground storm drainage pipeline and to conduct water through the same (collectively “Utility Improvements”), including a right of ingress and egress over and across a portion of the Property, as depicted in Exhibit A (“Easement Area”). No structures, including buildings, roof overhangs and swimming pools, will be permitted or constructed within or over any drainage easement. No trees may be planted therein. Said access easement must be kept clear for potential future use.

WHEREAS, the conveyance of the Easement to Grantee is authorized by the California Education Code. Pursuant to Education Code section 17556, a school district governing board may dedicate or convey to any public corporation or private corporation engaged in the public utility business an easement to lay, construct, reconstruct, maintain, and operate water, sewer, gas, or storm drain pipes or ditches, electric or telephone lines, and access roads used in connection therewith, over and upon any land belonging to the school district, upon such terms and conditions as agreed to by the parties.

WHEREAS, the dedication and conveyance of an easement pursuant to Education Code section 17556 et seq. is a two-step process. The first step is for the Board to adopt a resolution at a meeting of the Board declaring its intention to convey the easement and set a public hearing to be held not less than 10 days thereafter (Education Code § 17557). The second step is for the Board to: (1) hold the public hearing on the question of making the dedication or conveyance of the easement; and (2) adopt a resolution to authorize and direct the execution of a deed of dedication or conveyance of the easement and to deliver it (Education Code § 17559). The resolution must be adopted by at least a two-thirds vote of all of the Board members (Education Code § 17557, 17559).

WHEREAS, the Board completed the first step of the process by adopting, at its Board meeting on August 7, 2024, Resolution No. 4002 declaring its intention to convey the Easement to Grantee and setting a public hearing to be held at the Board meeting on August 28, 2024.

WHEREAS, at the Board meeting on August 28, 2024, the Board will take action to complete the second step in the process by adopting this Resolution and approving and authorizing the actions set forth below.

WHEREAS, no protest has been filed under Education Code section 17560.

THEREFORE, BE IT RESOLVED that the District’s Governing Board hereby:

1. Declares and adopts the foregoing recitals as true and correct.
2. Pursuant to Education Code section 17556 et seq., approves the conveyance of the Easement on, across, and upon the Easement Area to Grantee as set forth in the agreement between Grantee and District (“Easement Agreement”).
3. Authorizes and directs the Superintendent or designee to: (1) execute and deliver to Grantee the Easement Agreement and other documents as may be necessary to convey the Easement to Grantee, with such modifications thereto as the Superintendent or designee determines appropriate and agreed upon with Grantee; and (2) take such actions and execute such other documents as may be necessary to carry out and complete the Easement Agreement and the transaction contemplated by this Resolution.
4. This Resolution shall take effect immediately upon its adoption.

THE FOREGOING RESOLUTION was adopted by the Governing Board of the Clovis Unified School District of Fresno County, California, at a regular meeting of said Board held on this 28th day of August, 2024, by the following vote:

AYES:

NOES:

ABSENT:

ABSTAIN:

Hugh Awtrey, President
Governing Board
Clovis Unified School District
Fresno County, California

I, Clinton Olivier, the Clerk of the Governing Board of the Clovis Unified School District, County of Fresno, State of California, do hereby certify that the foregoing is a true copy of the Resolution adopted by said Board at a regular meeting there, at the time and by the vote therein stated, which original resolution is on file in the office of said Board.

Clinton Olivier, Clerk
Governing Board
Clovis Unified School District
Fresno County, California

Doc# 85088, 07/2024

[ATTACH EXHIBIT A]

**RECORDING REQUESTED BY
FRESNO METROPOLITAN
FLOOD CONTROL DISTRICT**

**AND WHEN RECORDED RETURN TO:
FRESNO METROPOLITAN
FLOOD CONTROL DISTRICT
5469 East Olive Avenue
FRESNO, CALIFORNIA 93727**

**--NO FEE--
Benefit of Fresno Metropolitan
Flood Control District
Pursuant to Government Codes § 6103 and 27383**

SPACE ABOVE THIS LINE FOR RECORDERS USE ONLY

GRANT OF EASEMENT AND RIGHT-OF-WAY

THIS GRANT OF EASEMENT AND RIGHT-OF-WAY, is made and entered into this ___ day of _____, 20___ by and between Clovis Unified School District, a California unified school district, as Grantor, and Fresno Metropolitan Flood Control District, a California public corporation in the County of Fresno, State of California, as Grantee.

WITNESSETH

That Grantor, for good and valuable consideration, does hereby grant to Grantee a perpetual and exclusive easement in, through, over, and under that real property in the County of Fresno, State of California described in Exhibit "A" (the "Easement"), attached hereto and incorporated herein by this reference, to install, construct, operate, maintain, repair, remove and replace an underground storm drainage pipeline and to conduct water through the same, together with all rights necessary, convenient or incidental thereto, including a right of ingress thereto and egress therefrom over Grantor's property as described in Exhibit "B" hereto (the "Property"), provided that such access shall not unreasonably interfere with Grantor's enjoyment of the Property.

No structures (including, but not limited to, buildings, roof overhangs and swimming pools) shall be constructed within the Easement, and no trees may be planted therein, but shrubs and grasses may be planted and sidewalks and parking areas may be installed on the Easement. In the event the Grantee damages improvements thereto in the use of reasonable care and enjoyment of the Easement, it shall not be obligated to restore the same or be liable for any damages whatsoever related thereto.

This Easement shall “run with the land” and be binding upon and inure to the benefit of Grantor’s heirs, executors, administrators, assigns and successors.

IN WITNESS WHEREOF, Grantor has executed this Grant of Easement and Right-of-Way the day and year first above written.

“GRANTOR”
Clovis Unified School District,
a California unified school district

Michael Johnston
Associate Superintendent
Administrative Services

Date

EXHIBIT "A"

LEGAL DESCRIPTION OF STORM DRAIN EASEMENT

APN: 310-320-03ST

APN: 310-320-05ST

APN: 310-320-06ST

APN: 310-050-38T

That portion of the North half of the Southeast quarter of Section 25, Township 13 South, Range 21 East, Mount Diablo Base and Meridian, County of Fresno, State of California, more particularly described as follows:

COMMENCING at the East quarter corner of said Section 25;

Thence along the east line of said Southeast quarter, South 00° 19' 00" West, a distance of 733.97 feet;

Thence North 90° 00' 00" West, a distance of 52.00 feet to the **TRUE POINT OF BEGINNING**;

Thence North 90° 00' 00" West, a distance of 1173.42 feet;

Thence South 45° 00' 00" West, a distance of 108.14 feet;

Thence North 90° 00' 00" West, a distance of 1286.57 feet;

Thence North 01° 10' 48" East, a distance of 30.01 feet;

Thence North 90° 00' 00" East, a distance of 1273.52 feet;

Thence North 45° 00' 00" East, a distance of 108.14 feet;

Thence North 90° 00' 00" East, a distance of 1172.02 feet to a line being parallel with and 66.00 feet west of said east line;

Thence along said parallel line, South 00° 19' 00" West, a distance of 1.70 feet;

Thence South 44° 49' 39" East, a distance of 19.75 feet to a line parallel with and 52.00 feet west of said east line;



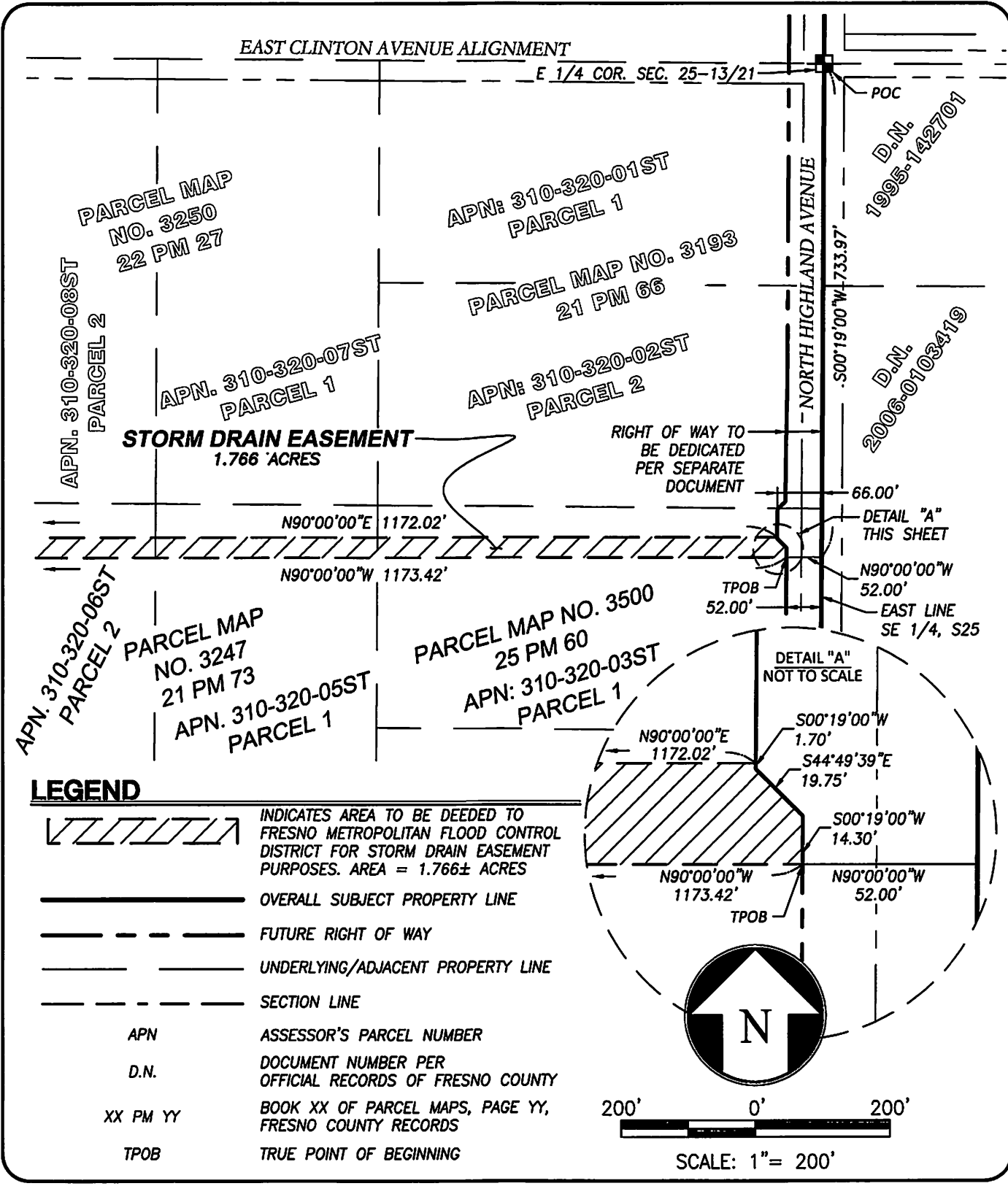

Thence along said parallel line, South 00° 19' 00" West, a distance of 14.30 feet to the **TRUE POINT OF BEGINNING**.

Containing 1.766 acres more or less.

L:\PROJECTS\2021\210323\ACAD\LEGALS\ON-SITE EASEMENT\02-DWG\210323-ONSITE_EX-C.DWG 7/19/2024 9:38 AM

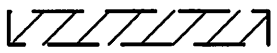

LEGEND

-  INDICATES AREA TO BE DEEDED TO FRESNO METROPOLITAN FLOOD CONTROL DISTRICT FOR STORM DRAIN EASEMENT PURPOSES. AREA = 1.766± ACRES
-  OVERALL SUBJECT PROPERTY LINE
-  FUTURE RIGHT OF WAY
-  UNDERLYING/ADJACENT PROPERTY LINE
-  SECTION LINE
- APN ASSESSOR'S PARCEL NUMBER
- D.N. DOCUMENT NUMBER PER OFFICIAL RECORDS OF FRESNO COUNTY
- XX PM YY BOOK XX OF PARCEL MAPS, PAGE YY, FRESNO COUNTY RECORDS
- TPOB TRUE POINT OF BEGINNING

PROJECT NO.: 210323
 DRAWN BY: GAI
 QA/QC BY: ASW
 SCALE: AS SHOWN
 PAGE NO.:
2 of 3

EXHIBIT "A"
STORM DRAIN EASEMENT



WWW.QKINC.COM
 1-800-955-7599
 BAKERSFIELD, CLOVIS, HANFORD, MERCED, PORTERVILLE, VISALIA
 © COPYRIGHT BY QUAD KNOPP, INC. UNAUTHORIZED USE PROHIBITED.

L:\PROJECTS\2021\210323\ACAD\LEGALS\ON-SITE EASEMENT\02-DWG\210323-ONSITE_EX-C.DWG 7/19/2024 9:36 AM

EAST CLINTON AVENUE ALIGNMENT

NORTH LEONARD AVENUE

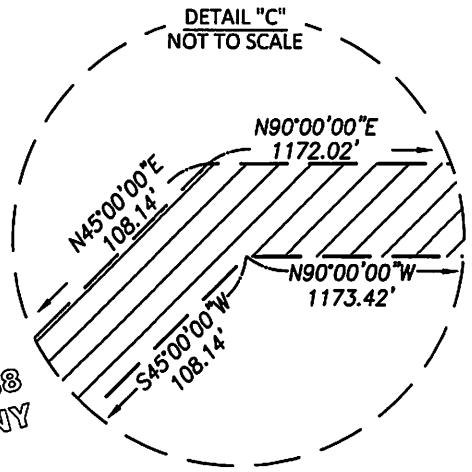
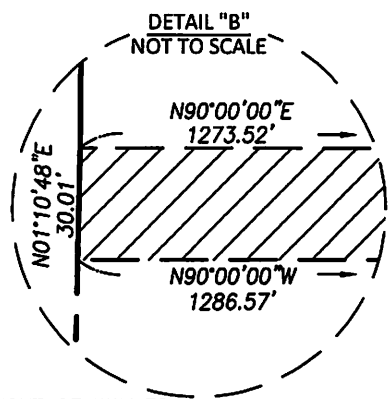

RIGHT OF WAY TO BE DEDICATED PER SEPARATE DOCUMENT

APN. 310-050-38
KUTNER COLONY
02 RS 08
LOT 8

WEST LINE LOT 7

STORM DRAIN EASEMENT
1.766 ACRES



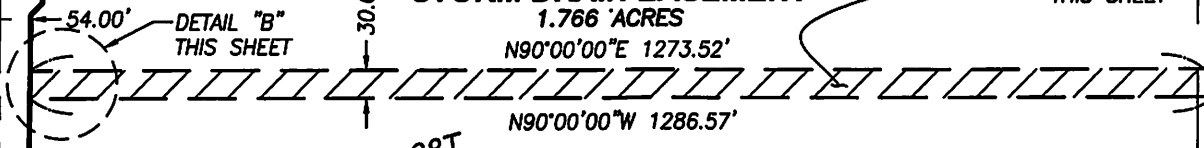

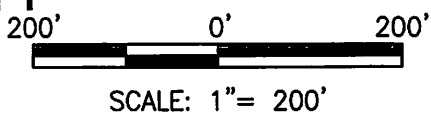

DETAIL "C" THIS SHEET



APN: 310-050-38T
KUTNER COLONY
02 RS 08
LOT 7



LEGEND

-  INDICATES AREA TO BE DEEDED TO FRESNO METROPOLITAN FLOOD CONTROL DISTRICT FOR STORM DRAIN EASEMENT PURPOSES. AREA = 1.766± ACRES
-  OVERALL SUBJECT PROPERTY LINE
-  FUTURE RIGHT OF WAY
-  UNDERLYING/ADJACENT PROPERTY LINE
-  EXISTING RIGHT OF WAY
-  SECTION LINE
- APN ASSESSOR'S PARCEL NUMBER
- D.N. DOCUMENT NUMBER PER OFFICIAL RECORDS OF FRESNO COUNTY.
- 02 RS 08 BOOK 02 OF RECORD OF SURVEY, PAGE 08 FRESNO COUNTY RECORDS.
- TPOB TRUE POINT OF BEGINNING

PROJECT NO.: 210323
 DRAWN BY: GAI
 QA/QC BY: ASW
 SCALE: AS SHOWN
 PAGE NO.:
3 OF 3

EXHIBIT "A"

STORM DRAIN EASEMENT



WWW.QKINC.COM
 1-800-855-7599
 BAKERSFIELD, CLOVIS, HANFORD, MERCED, PORTERVILLE, VISALIA
 © COPYRIGHT BY QUAD KNOPP, INC. UNAUTHORIZED USE PROHIBITED.

EXHIBIT "B"

LEGAL DESCRIPTION OF PROPERTY

Those portions of the North half of the Southeast quarter of Section 25, Township 13 South, Range 21 East, Mount Diablo Base and Meridian, in the County of Fresno, State of California, more particularly described as follows:

Parcel No. 1 of Parcel Map No. 3500, according to the map thereof recorded in Book 25 Page 60 of Parcel Maps, Fresno County Records.

TOGETHER WITH Parcel No. 1 of Parcel Map No. 3247, according to the map thereof recorded in Book 21 Page 73 of Parcel Maps, Fresno County Records.

TOGETHER WITH Parcel No. 2 of Parcel Map No. 3247, according to the map thereof recorded in Book 21 Page 73 of Parcel Maps, Fresno County Records.

TOGETHER WITH Lots 7 & 8 of Kutner Colony according to the map thereof recorded in Book 2 at Page 8, of Record of Surveys, Fresno County Records.

CUSD Board Agenda Item

Agenda Item: 09

Title: Resolution No. 4004 - Exemption to the Separation-from-Service Requirement for One Certificated Retiree

CONTACT: None

FOR INFORMATION: August 14, 2024

FOR ACTION: August 28, 2024

RECOMMENDATION:

Adopt Resolution No. 4004, approving an exemption to the separation-from-service requirement for the 2024-25 school year (Education Code § 24214.5 or 26812).

DISCUSSION:

California Education Code sections 24214.5 or 26812 authorizes the Governing Board to permit a 180-calendar-day separation-from-service requirement for all retired CalSTRS members and participants receiving an annuity. There is, however, a narrow exemption from the 180-calendar-day separation-from-service requirement if the retired member is appointed to a critically needed position.

At this time, the District is in critical need of English as a Second Language (ESL) teachers to provide services to students and collaborate with educators, parents and other professionals to create a safe, healthy and supportive learning environment. Currently, a shortage of ESL teachers exists nationwide, statewide and districtwide.

Recommended for this position is retired veteran teacher Melanie Franz who served the District for 30 years. Ms. Franz is a credentialed teacher who would be able to provide critical services for our ESL students. Due to growth and the existing shortage, there is a critical need to utilize a qualified retiree working outside the scope of her previous position. It is recommended that the Governing Board meet this critical need by requesting an exemption to the 180-day wait period for a CalSTRS retiree.

FISCAL IMPACT:

REVISIONS:

ATTACHMENTS:

Description	Upload Date
Resolution_4004_-_Exemption_to_the_Separation_from_Service_Melanie_Franz-Adult_School-1-.pdf	12-19-2024

**RESOLUTION NO. 4004
BEFORE THE GOVERNING BOARD
OF THE CLOVIS UNIFIED SCHOOL DISTRICT
FRESNO COUNTY, CALIFORNIA**

**RESOLUTION FOR THE EXEMPTION TO THE SEPARATION
FROM SERVICE REQUIREMENT FOR THE 2024-25 SCHOOL YEAR
(Education Code §24214.5 or 26812)**

WHEREAS, pursuant to Education Code sections 24214.5 or 26812, there is a 180-calendar-day separation-from-service requirement for all retired CalSTRS members and participants; and

WHEREAS, all retired CalSTRS members and participants are subject to a restriction if they perform retired member activities as defined by section 22164.5 of the Education Code or retired participant activities as defined by section 26135.7 of the Education Code, during the first 180 calendar days after their most recent retirement; and

WHEREAS, if the retired CalSTRS member or participant performed retired member or participant activities during this period, CalSTRS will reduce his or her retirement benefit or annuity one dollar for each dollar earned for performing retired member or participant activities during the 180-day period; and

WHEREAS, there is an exemption from the 180-calendar-day separation-from-service-requirement for a member or participant who retires from service and is at or above normal retirement age; and

WHEREAS, in order to qualify for this narrow exemption, the employer must appoint the retired member or participant to a crucially needed position that has been approved by the governing body of the employer in a public meeting as reflected in a resolution; and

WHEREAS, this approval by the governing body of the employer in a public meeting as reflected in a resolution must be finalized and communicated to CalSTRS before the member or participant commences to perform retired member or participant activities; and

WHEREAS, the Superintendent must complete the Request for Separation-from-Service-Requirement Exemption Form, which must be submitted to CalSTRS and received by CalSTRS before the member or participant commences to perform retired member or participant activities.

THEREFORE, BE IT RESOLVED that this Board does provide public notice that the District is in critical need of teachers in the specialized field of English as a Second Language (ESL) for Clovis Adult Education. Recommended for this position is veteran teacher Melanie Franz, who served the District for 30 years. Ms. Franz is a credentialed teacher that will provide instruction in ESL as part of our multi-level class which serves all levels of students as they enter our leveled ESL classes. In addition, Ms. Franz will provide services in our Adult Basic Education classes to further support our students at Clovis Adult Education. This critical need is paramount for the continued growth and development of our adult learners who rely on high-quality ESL education to improve their career prospects and integration into the community. Therefore, it is recommended that the Governing Board meets this critical need by requesting an exemption to the 180-day wait period for a CalSTRS retiree.

BE IT ALSO RESOLVED that the Board wishes to meet this critical need by hiring Melanie Franz, a member or participant who retired for service less than 180 days ago.

BE IT ALSO RESOLVED that this appointment is needed to fill this critical need before the 180-calendar-day separation-from-service requirement is fulfilled.

BE IT ALSO RESOLVED that this member or participant did not receive a retirement incentive or any financial inducement to retire from any public employer.

BE IT ALSO RESOLVED that the retired member's or participant's termination of employment is not the basis for the need to acquire his or her services.

BE IT ALSO RESOLVED that the earnings for retired member activities during the 180 calendar days will still be subject to the annual postretirement earnings limit for the Defined Benefit Program.

BE IT ALSO RESOLVED that this member or participant will not commence to perform retired member or participant activities before this approval is authorized by the governing body of the employer in a public meeting as reflected in a resolution and received by CalSTRS.

BE IT ALSO RESOLVED that this member or participant will not commence to perform retired member or participant activities before the Superintendent completes the Request for Separation-from-Service Requirement Exemption Form and this is transmitted to and received by CalSTRS.

THE FOREGOING RESOLUTION was adopted by the Governing Board of the Clovis Unified School District of Fresno County, State of California, at a regular meeting of said Board duly held on this 28th day of August, 2024, by the following vote:

AYES:

NOES:

ABSENT:

ABSTAIN:

Hugh Awtrey, President
Governing Board
Clovis Unified School District
Fresno County, California

I, Clinton Olivier, Clerk of the Governing Board of the Clovis Unified School District, County of Fresno, State of California, do hereby certify that the foregoing is a true copy of the resolution adopted by said Board at as regular meeting thereof, at the time and by the vote therein stated, which original resolution is on file in the office of said Board.

Clinton Olivier, Clerk
Governing Board
Clovis Unified School District
Fresno County, California

CUSD Board Agenda Item

Agenda Item: O 10

Title: Resolutions No. 4005 and 4006 – Exemptions to the Separation-from-Service Requirement for Two Classified Retirees

CONTACT: None

FOR INFORMATION: August 14, 2024

FOR ACTION: August 28, 2024

RECOMMENDATION:

Adopt Resolutions No. 4005 and 4006 authorizing Clovis Unified School District to hire two CalPERS retirees prior to the 180-day post-retirement waiting period.

DISCUSSION:

A retiree can return to work for a school district employer without reinstating into active service and without an impact on their pension benefit if they return to work for one of the following reasons (Government Code Section 7522.56):

- An emergency to prevent stoppage of public business.
- The retiree has skills needed to perform work of limited duration.

A public agency retiree cannot return to work for at least 180 days after retirement unless the following conditions are met (Government Code 7522.56):

- The employer certifies that the appointment is necessary to fill a critically needed position before 180 days have passed.
- The appointment has been approved by the governing body of the employer in a public meeting.

The District deems it essential to appoint retirees John Meyers and Luis Galindo to fulfill the vital role of Student Resource Officers, which are currently vacant and urgently required. These positions carry the responsibility of providing critical safety needs for our schools and community. The District remains actively engaged in recruiting for these positions. Officers Meyers and Galindo possess the necessary experience and expertise to carry out these responsibilities until the vacancies are filled. It is important to note that the employment of these retirees will be restricted to 960 hours per officer for the 2024-25 fiscal year.

FISCAL IMPACT:

No fiscal impact.

REVISIONS:

ATTACHMENTS:

Description

Upload Date

[Resolution_4005_-_Exemption_to_the_Separation_from_Service_Meyers_-_SRO_CalPERS-1-.pdf](#)

12-19-2024

[Resolution_4006_-_Exemption_to_the_Separation_from_Service_Galindo_-_SRO_CalPERS-1-.pdf](#)

12-19-2024

**RESOLUTION NO. 4005
BEFORE THE GOVERNING BOARD
OF THE CLOVIS UNIFIED SCHOOL DISTRICT
FRESNO COUNTY, CALIFORNIA**

**RESOLUTION FOR THE EXEMPTION TO THE
SEPARATION-FROM-SERVICE REQUIREMENT
FOR THE 2024-25 SCHOOL YEAR
(Government Code § 7522.56 and 21221)**

WHEREAS, in compliance with Government Code section 7522.56 of the Public Employees' Retirement Law, the Clovis Unified School District's Governing Board must provide CalPERS this certification resolution when hiring a retiree before 180 days have passed since his or her retirement date; and

WHEREAS, John Meyers (ID No. 1621) retired from Clovis Unified School District in the position of School Resource Officer, effective June 7, 2024; and

WHEREAS, Government Code section 7522.56 requires that post-retirement employment commence no earlier than 180 days after the retirement date, which is December 5, 2024, without this certification resolution; and

WHEREAS, Government Code section 7522.56 provides that this exception to the 180-day wait period shall not apply if the retiree accepts any retirement-related incentive; and

WHEREAS, the Clovis Unified School District and John Meyers certify that John Meyers has not and will not receive a Golden Handshake or any other retirement-related incentive; and

WHEREAS, the Clovis Unified School District hereby appoints John Meyers as an interim appointment retired annuitant to the vacant position of School Resource Officer for the Clovis Unified School District under Government Code section 21221(h), effective August 29, 2024; and

WHEREAS, an appointment under Government Code section 21221(h) requires an active, publicly posted recruitment for a permanent replacement; and

WHEREAS, the current status of this recruitment is ongoing, in process and posted with insufficient applicants; and

WHEREAS, this Government Code section 21221(h) appointment shall only be made once and therefore will end on June 6, 2025; and

WHEREAS, the entire employment agreement, contract or appointment document between John Meyers and the Clovis Unified School District has been reviewed by this body and is attached herein; and

WHEREAS, no matters, issues, terms or conditions related to this employment and appointment have been or will be placed on a consent calendar; and

WHEREAS, the employment shall be limited to 960 hours per fiscal year; and

WHEREAS, the compensation paid to retirees cannot be less than the minimum nor exceed the maximum monthly base salary paid to other employees performing comparable duties, divided by 173.333 to equal the hourly rate; and

WHEREAS, the maximum base salary for this position is \$6,211.80 and the hourly equivalent is \$35.70 and the minimum base salary for this position is \$5,115.60 and the hourly equivalent is \$29.40; and

WHEREAS, the hourly rate paid to John Meyers will be \$35.70; and

WHEREAS, John Meyers has not and will not receive any other benefit, incentive, compensation in lieu of benefit or other form of compensation in addition to this hourly pay rate.

THEREFORE, BE IT RESOLVED THAT the Clovis Unified School District's Governing Board hereby certifies the nature of the employment of John Meyers as described herein and detailed in the attached employment requisition and that this appointment is necessary to fill the critically needed position of Student Resource Officer for the Clovis Unified School District by August 29, 2024. This position provides a critical safety need for our schools and community and the work is necessary to fill these positions sooner than the 180 days. The work performed will be peace officer annuitant work.

THE FOREGOING RESOLUTION was adopted by the Governing Board of the Clovis Unified School District of Fresno County, state of California, at a regular meeting of said Board held on this 28th day of August, 2024, by the following vote:

AYES:

NOES:

ABSENT:

ABSTAIN:

Hugh Awtrey, President
Governing Board
Clovis Unified School District
Fresno County, California

I, Clinton Olivier, Clerk of the Governing Board of the Clovis Unified School District, County of Fresno, State of California, do hereby certify that the foregoing is a true copy of the resolution adopted by said Board at as regular meeting thereof, at the time and by the vote therein stated, which original resolution is on file in the office of said Board.

Clinton Olivier, Clerk
Governing Board
Clovis Unified School District
Fresno County, California

**RESOLUTION NO. 4006
BEFORE THE GOVERNING BOARD
OF THE CLOVIS UNIFIED SCHOOL DISTRICT
FRESNO COUNTY, CALIFORNIA**

**RESOLUTION FOR THE EXEMPTION TO THE SEPARATION
FROM SERVICE REQUIREMENT FOR THE 2024-25 SCHOOL YEAR
(G.C Sections §7522.56 & 21224)**

WHEREAS, in compliance with Government Code section 7522.56 of the Public Employees' Retirement Law, the Clovis Unified School District's Governing Board must provide CalPERS this certification resolution when hiring a retiree before 180 days has passed since his or her retirement date; and

WHEREAS, Luis Galindo (ID No. 9876) retired from Clovis Unified School District in the position of School Resource Officer, effective July 3, 2024; and

WHEREAS, Government Code section 7522.56 requires that post-retirement employment commence no earlier than 180 days after the retirement date, which is December 31, 2024, without this certification resolution; and

WHEREAS, Government Code section 7522.56 provides that this exception to the 180-day wait period shall not apply if the retiree accepts any retirement-related incentive; and

WHEREAS, the Clovis Unified School District and Luis Galindo certify that Luis Galindo has not and will not receive a Golden Handshake or any other retirement-related incentive; and

WHEREAS, the Clovis Unified School District hereby appoints Luis Galindo as an interim appointment retired annuitant to the vacant position of School Resource Officer for the Clovis Unified School District under Government Code section 21221(h), effective August 29, 2024; and

WHEREAS, an appointment under Government Code section 21221(h) requires an active, publicly posted recruitment for a permanent replacement; and

WHEREAS, the current status of this recruitment is ongoing, in process and posted with insufficient applicants; and

WHEREAS, this Government Code section 21221(h) appointment shall only be made once and therefore will end on June 5, 2025; and

WHEREAS, the entire employment agreement, contract or appointment document between Luis Galindo and the Clovis Unified School District has been reviewed by this body and is attached herein; and

WHEREAS, no matters, issues, terms or conditions related to this employment and appointment have been or will be placed on a consent calendar; and

WHEREAS, the employment shall be limited to 960 hours per fiscal year; and

WHEREAS, the compensation paid to retirees cannot be less than the minimum nor exceed the maximum monthly base salary paid to other employees performing comparable duties, divided by 173.333 to equal the hourly rate; and

WHEREAS, the maximum base salary for this position is \$6,211.80 and the hourly equivalent is \$35.70 and the minimum base salary for this position is \$5,115.60 and the hourly equivalent is \$29.40; and

WHEREAS, the hourly rate paid to Luis Galindo will be \$35.70; and

WHEREAS, Luis Galindo has not and will not receive any other benefit, incentive, compensation in lieu of benefit or other form of compensation in addition to this hourly pay rate.

THEREFORE, BE IT RESOLVED THAT the Clovis Unified School District's Governing Board hereby certifies the nature of the employment of Luis Galindo as described herein and detailed in the attached employment requisition and that this appointment is necessary to fill the critically needed position of Student Resource Office for the Clovis Unified School District by August 29, 2024. This position provides a critical safety need for our schools and community and the work is necessary to fill these positions sooner than the 180 days. The work performed will be peace officer annuitant work.

THE FOREGOING RESOLUTION was adopted by the Governing Board of the Clovis Unified School District of Fresno County, State of California, at a regular meeting of said Board held on this 28th day of August, 2024, by the following vote:

AYES:

NOES:

ABSENT:

ABSTAIN:

Hugh Awtrey, President
Governing Board
Clovis Unified School District
Fresno County, California

I, Clinton Olivier, Clerk of the Governing Board of the Clovis Unified School District, County of Fresno, State of California, do hereby certify that the foregoing is a true copy of the resolution adopted by said Board at as regular meeting thereof, at the time and by the vote therein stated, which original resolution is on file in the office of said Board.

Clinton Olivier, Clerk
Governing Board
Clovis Unified School District
Fresno County, California

CUSD Board Agenda Item

Agenda Item: O 11

Title: Award of Bid - Services

CONTACT: Michael Johnston

FOR INFORMATION: August 7, 2024

FOR ACTION: August 28, 2024

RECOMMENDATION:

Award the following Request for Proposal (RFP) No 2998 - Charter Bus Services to various service providers.

DISCUSSION:

RFP No. 2998 - Four (4) proposals were received and opened on August 7, 2024. Award to all service providers per attached tabulation.

FISCAL IMPACT:

As noted above.

REVISIONS:

ATTACHMENTS:

Description

Upload Date

[RFP_No_2998_-_Evaluation_Score_Sheet_-1-.pdf](#)

12-19-2024

Request for Proposal
 #2998- Charter Bus Services

Evaluation Criteria	Maximum Points	Busloop	Vol-Ten dba Delta Charter	Awesome Charter	Golden Eagle Charter
Price	45	45	40	33	33
Vendor Questionnaire	30	27	27	24	25
References	15	13	11	15	15
Response to RFP	10	9	10	10	6
Total Possible Points	100	94	88	82	78

The highest-ranked bidder might not be able to fulfill all of the District's needs at any specific date or time. Contracts will be awarded to all bidders, who will then have the chance to provide trips according to their ranking.

CUSD Board Agenda Item

Agenda Item: P 1

Title: Annual Agreement with KEY2ED Professional Development

CONTACT: Norm Anderson

FOR INFORMATION: August 28, 2024

FOR ACTION: September 11, 2024

RECOMMENDATION:

Authorize Clovis Unified School District to enter into an agreement with KEY2ED Professional Development for the purpose of utilizing their services to train staff in the Facilitated Individualized Education Plan Program.

DISCUSSION:

KEY2ED is the Professional Development Company that Clovis Unified School District has worked with for several years. They have 20+ years of special education experience. Participants will complete these trainings at one of two workshops during the 2024-25 school year.

This item will appear on the September 11, 2024, Consent Agenda.

FISCAL IMPACT:

The contract will not exceed \$34,400. The amount of \$15,157 has been included in the Alternate Dispute Resolution Grant with the remainder of the cost included in the 2024-25 Special Education Budget.

REVISIONS:

ATTACHMENTS:

Description

Upload Date

CUSD Board Agenda Item

Agenda Item: P 2

Title: Amended Board Policies No. 1312.2, 1312.3, 5030, 5111 and 6158

CONTACT: Corrine Folmer

FOR INFORMATION: August 28, 2024

FOR ACTION: September 11, 2024

RECOMMENDATION:

Adopt amended Board Policies No. 1312.2, 1312.3, 5030, 5111 and 6158.

DISCUSSION:

Pursuant to Board Bylaw No. 9310, the Superintendent or designee reviews board policies on a continual basis and recommends amendments to reflect changes.

The Superintendent or designee has conducted a review of and recommends that the Board adopt the proposed amendments to Board Policies No. 1312.2, 1312.3, 5030, 5111 and 6158. The proposed amendments are as set forth in each amended Board Policy, a copy of which will be provided to the Board on or before the September 11, 2024, Board meeting.

FISCAL IMPACT:

No fiscal impact.

REVISIONS:

ATTACHMENTS:

Description

Upload Date

CUSD Board Agenda Item

Agenda Item: P 3

Title: Biennial AB 3141 Health and Benefits Actuarial

CONTACT: Michael Johnston

FOR INFORMATION: August 28, 2024

FOR ACTION: September 11, 2024

RECOMMENDATION:

Disclosure Approve funding the projected 2023-24 retiree health and welfare benefit costs on an incurred "pay-as-you-go" basis with the understanding sufficient funds to cover annual costs have been included in the 2024-25 Budget.

DISCUSSION:

Governmental Accounting Standards Board Statement 75 (GASB 75) requires government agencies to account for Other Post-Employment Benefits (OPEB) in their financial statements using the full accrual method. Currently, the District pays for the OPEB costs annually on a pay-as-you-go basis. Beginning with the 2008-09 fiscal year financial statements, the District has been required to show the liability of these benefits on its financial statements.

In order to comply with the requirements of GASB 75, the District secured the services of Foster & Foster Actuaries and Consultants, to perform an actuarial study of the District's retiree health liabilities or OPEB. This actuarial report is required at least once every two years.

The results of the actuarial study will be provided to all members of the Governing Board with their agenda materials for the September 11, 2024, meeting.

FISCAL IMPACT:

REVISIONS:

ATTACHMENTS:

Description

Upload Date

CUSD Board Agenda Item

Agenda Item: P 4

Title: Annual 2023-24 Financial Report

CONTACT: Michael Johnston

FOR INFORMATION: August 28, 2024

FOR ACTION: September 11, 2024

RECOMMENDATION:

Accept the 2023-24 Annual Financial Report, as submitted.

DISCUSSION:

The 2023-24 Annual Financial Report reflects the District's unaudited actual revenues and expenditures as of June 30, 2024.

Each quarter, Business Services updates the Board as to the current financial condition of the District in relation to revenues and expenses along with the projected fund balance.

A link to the 2023-24 Annual Financial Report will be provided to the Board prior to the September 11, 2024, Governing Board meeting.

FISCAL IMPACT:

REVISIONS:

ATTACHMENTS:

Description

Upload Date

CUSD Board Agenda Item

Agenda Item: P 5

Title: Resolution No. 4008 – Annual Budget Transfers 2023-24

CONTACT: Michael Johnston

FOR INFORMATION: August 28, 2024

FOR ACTION: September 11, 2024

RECOMMENDATION:

Adopt Resolution No. 4008 authorizing budget transfers for the 2023-24 fiscal year for funds operated by the District.

DISCUSSION:

In order to properly account for operating revenues and expenditures that are approved after the adoption of the annual school district budget, the California Education Code allows school districts to transfer funds between/among revenue and expenditure classifications provided a resolution is adopted. Resolution No. 4008 authorizes the District to make the final 2023-24 budget transfers that are necessary for the following District funds:

- General Fund
- Charter School Fund
- Adult Education Fund
- Child Development Fund
- Food Services Fund
- Deferred Maintenance Fund
- Developer Fee Fund
- Building Fund
- State School Facility Fund
- Self-Insurance Fund
- Workers' Compensation Fund
- Special Reserve for Capital Outlay Fund
- Bond Interest and Redemption Fund

The 2023-24 Budget Transfer Report will be accessible prior to the September 11, 2024, Board meeting on the CUSD website at: <https://www.cusd.com/FinancialReports.aspx>.

FISCAL IMPACT:

REVISIONS:

ATTACHMENTS:

Description

[Resolution_No._4008_Annual_Budget_Transfers_2023-24.pdf](#)

Upload Date

12-19-2024

**RESOLUTION NO. 4008
BEFORE THE GOVERNING BOARD
OF THE CLOVIS UNIFIED SCHOOL DISTRICT
FRESNO COUNTY, CALIFORNIA**

IN THE MATTER OF APPROVING THE 2023-24 BUDGET TRANSFERS

WHEREAS, the Governing Board of the Clovis Unified School District duly adopted 2023-24 budgets that are necessary for all District funds at its June 14, 2023, meeting; and

WHEREAS, because of modifications to both revenue and expenditure projections to all of the aforementioned funds; and

WHEREAS, Education Code Section 42600 authorizes the Board to make necessary budget transfers to reflect actual revenues and expenditures for the aforementioned funds; and

WHEREAS, it will be necessary to make budget transfers in order to properly account for the payment of obligations of the school district incurred during the 2023-24 fiscal year.

THEREFORE, BE IT RESOLVED that the Board authorize such transfers, as attached, to revenue and expenditure classifications of the General Fund, Charter School Fund, Adult Education Fund, Child Development Fund, Food Services Fund, Deferred Maintenance Fund, Developer Fee Fund, Building Fund, State School Facility Fund, Self-Insurance Fund, Workers' Compensation Fund, Special Reserve for Capital Outlay Fund, and Bond Interest and/or Redemption Fund for the 2023-24 fiscal year.

THE FOREGOING RESOLUTION was adopted by the Governing Board of the Clovis Unified School District of Fresno County, State of California, at a meeting of said Board held on the 11th day of September, 2024, by the following vote:

AYES:

NOES:

ABSENT:

ABSTAIN:

Hugh Awtrey, President
Governing Board
Clovis Unified School District
Fresno County, California

I, Clinton Olivier, Clerk of the Governing Board of the Clovis Unified School District, County of Fresno, State of California, do hereby certify that the foregoing is a true copy of the resolution adopted by said Board at a regular meeting thereof, at the time and by the vote therein stated, which original resolution is on file in the office of said Board.

Clinton Olivier, Clerk
Governing Board
Clovis Unified School District
Fresno County, California

CUSD Board Agenda Item

Agenda Item: P 6

Title: Resolution No. 4009 – Annual Recalculated 2023-24 Gann Limit Appropriation and Estimated 2024-25 Gann Limit Appropriation

CONTACT: Michael Johnston

FOR INFORMATION: August 28, 2024

FOR ACTION: September 11, 2024

RECOMMENDATION:

Adopt Resolution No. 4009 to recalculate the 2023-24 Gann Limit Appropriation and estimate the 2024-25 Gann Limit Appropriation.

DISCUSSION:

The Gann Limit, named for Paul Gann, the author of Proposition 4 which amended the State Constitution to establish this limit, is intended to constrain the growth in state and local government spending by linking year-to-year changes in expenditures to changes in inflation (represented by per capita personal income) and population (represented by average daily attendance (ADA) for schools). Established in 1979 following the enactment of Proposition 13 and subsequently amended by Proposition 111, the Gann Limit has become a largely pro forma calculation that no longer constrains governmental expenditures. This is because the limit has grown significantly faster than appropriations subject to the limit.

Education Code Section 42132 requires that on or before September 15 of each year, the governing board adopt a resolution to identify the estimated appropriations limit for the current fiscal year and the actual appropriations limit for the preceding fiscal year.

Clovis Unified is required to perform Gann Limit calculations by the State Constitution, but it is also important for the District to complete these calculations to identify how much state aid counts toward its Gann Limit and, ultimately, the state's own Gann Limit.

The worksheet reflecting the recalculated 2023-24 Gann Limit Appropriation for the District and the estimated Gann Limit Appropriation for 2024-25 will be provided to the Governing Board prior to the September 11, 2024, Governing Board meeting.

FISCAL IMPACT:

REVISIONS:

ATTACHMENTS:

Description

Upload Date

[Resolution_No._4009_Annual_Recalculated_2023-24_Gann_Limit_Appropriation.pdf](#)

12-19-2024

**RESOLUTION NO. 4009
BEFORE THE GOVERNING BOARD
OF THE CLOVIS UNIFIED SCHOOL DISTRICT
FRESNO COUNTY, CALIFORNIA**

**IN THE MATTER TO RECALCULATE
THE 2023-24 GANN LIMIT APPROPRIATION
AND ESTIMATE THE 2024-25 GANN LIMIT APPROPRIATION**

WHEREAS, in November of 1979, the California electorate did adopt Proposition 4, commonly called the Gann Amendment, which added Article XIII-B to the California Constitution; and

WHEREAS, the provisions of that Article establish maximum appropriation limitations, commonly called “Gann Limits,” for public agencies, including school districts; and

WHEREAS, the Clovis Unified School District must establish a revised Gann Limit for the 2023-24 fiscal year and a projected Gann Limit for the 2024-25 fiscal year in accordance with the provisions of Article XIII-B and applicable statutory law.

THEREFORE, BE IT RESOLVED that this Governing Board does provide public notice that the attached calculations and documentation of the Gann Limits for the 2023-24 and 2024-25 fiscal years are made in accord with applicable constitutional and statutory law.

BE IT ALSO RESOLVED that this Governing Board does hereby declare that the appropriations in the Budget for the 2023-24 and 2024-25 fiscal years do not exceed the limitations imposed by Proposition 4.

BE IT FURTHER RESOLVED that the Superintendent provides copies of this resolution along with the appropriate attachments to interested citizens of this District.

THE FOREGOING RESOLUTION was adopted by the Governing Board of the Clovis Unified School District of Fresno County, State of California, at a meeting of said Board held on the 11th day of September, 2024, by the following vote:

AYES:

NOES:

ABSENT:

ABSTAIN:

Hugh Awtrey, President
Governing Board
Clovis Unified School District
Fresno County, California

I, Clinton Olivier, Clerk of the Governing Board of the Clovis Unified School District, County of Fresno, State of California, do hereby certify that the foregoing is a true copy of the resolution adopted by said Board at a regular meeting thereof, at the time and by the vote therein stated, which original resolution is on file in the office of said Board.

Clinton Olivier, Clerk
Governing Board
Clovis Unified School District
Fresno County, California

CUSD Board Agenda Item

Agenda Item: P 7

Title: Award of Bid - Construction

CONTACT: Michael Johnston

FOR INFORMATION: August 28, 2024

FOR ACTION: September 11, 2024

RECOMMENDATION:

A recommendation for Bid 2999 - Campus Security Improvements Phase III will be brought to the Governing Board for action at a future date.

DISCUSSION:

Bid #	Description	First Bid Advertisement Date	Bid Due Date and Time	Funding Source
2999	Campus Security Improvements Phase III	07/24/2024	08/21/2024 11:00 AM	Bond Funds

FISCAL IMPACT:

As noted above.

REVISIONS:

ATTACHMENTS:

Description

Upload Date