



GOVERNING BOARD MEETING
August 7, 2024

Clovis North Educational Center Lecture Hall
2770 East International Avenue, Fresno, CA 93730

5:30 P.M. – CLOSED SESSION
6:30 P.M. – PUBLIC SESSION

Members of the public who wish to provide public comments must do so in-person during the board meeting. **Please complete and submit a Public Comment Form before the start of the Public Session on the day of the meeting.** The Public Comment Form is available outside the board meeting room on the day of the meeting. During the meeting, speakers who have requested to address the Board will be called to do so. Comments on items that are on the agenda are to be made when the item is called by the Board President. Comments on matters that are not on the agenda are to be made during the Public Presentations. Pursuant to Board Bylaw No. 9323, each speaker generally has up to 2 minutes to speak. The Board President may adjust the time allotted for each speaker and limit the total time for public comment. No speaker may yield his or her time to another speaker.

Regular Meeting
AGENDA

Additional information regarding this agenda may be viewed through the District's website at <https://www.cusd.com/BoardMeetingsAgendasArchives.aspx>

In compliance with the Americans with Disabilities Act, if you need special assistance to access the Board meeting room or to otherwise participate at this meeting, including auxiliary aids or services, please contact the Superintendent's Office at 327-9100. Notification at least 48 hours prior to the meeting will enable the District to make reasonable arrangements to ensure accessibility to the Board meeting.

Public records relating to an open session agenda item of a regular meeting that are distributed within 72 hours prior to the meeting will be available for public inspection at the District Office, 1450 Herndon Avenue, Clovis, California.

An invocation may be held prior to the start of the Board meeting. Attendance during and participation in the invocation are optional and voluntary. No students, parents, members of the public, Board members, student board member, or employees are required to attend or participate in the invocation.

INVOCATION

A. CALL TO ORDER

B. ROLL CALL

C. ADOPTION OF AGENDA

D. CLOSED SESSION

- 1. CONFERENCE WITH LEGAL COUNSEL – ANTICIPATED LITIGATION – Significant Exposure to Litigation (Pursuant to Subdivision (d)(2) of Gov't. Code §54956.9) – 1 case**

2. CONFERENCE WITH LEGAL COUNSEL – EXISTING LITIGATION (Gov't Code §54956.9(d)) - SA-CE-3040-E, SA-CE-3047-E, SA-CE-3051-E
3. CONFERENCE WITH LABOR NEGOTIATORS (Education Code §54957.6) Agency Negotiator – Corrine Folmer, Ed.D., Supt. Negotiating Parties – Contracted Emps., Cert. Mgmt., Cert. Teachers, Class. Emps., Class. Mgmt. and Ops. Unit (Represented by CSEA Clovis Chapter 250)
4. APPOINTMENT/EMPLOYMENT OF INDIVIDUALS IN POSITIONS LISTED IN BOARD POLICY EXHIBITS NO. 4151.10, 4251.10, 4351.10, 4151.21, 4151.22, 4151.23, AND 4251.10 (Gov't. Code §54957)
5. PUBLIC EMPLOYEE DISCIPLINE/DISMISSAL/RELEASE/SUSPENSION (Gov't. Code §54957)
6. STUDENT DISCIPLINE AND OTHER CONFIDENTIAL STUDENT MATTERS (Education Code §48900 et seq. and §35146)

E. RECONVENE FOR PUBLIC SESSION

F. RECOGNITION OF VISITORS

G. PLEDGE OF ALLEGIANCE

H. CLOSED SESSION MOTIONS

I. SUPERINTENDENT'S REPORT

J. PUBLIC PRESENTATIONS

This time is reserved for individuals who may wish to address the Board regarding a matter that is not included on the agenda. Please note that because the items brought up by the public during this time are not on the agenda, the Governing Board may not discuss or act upon such items.

K. PUBLIC HEARINGS

1. Public Hearing Regarding the Conveyance of Public Utility Easement to Pacific Gas and Electric Company, APN 574-130-01T
Conduct a Public Hearing no earlier than 6:45 p.m. at 2770 East International Avenue, Fresno, 93730, regarding the conveyance of a public utility easement to Pacific Gas and Electric Company, APN 574-130-01T.

L. CONSENT

1. Conference Requests
Approve the Conference Requests, as submitted.
2. Fundraiser Requests
Approve the Fundraiser Requests, as submitted.
3. Student Trip Requests
Approve the Student Trip Requests, as submitted.
4. Voluntary Community Recreation Programs
Approve the Voluntary Community Recreation Programs, as submitted.
5. July 17, 2024, Governing Board Meeting Minutes
Approve the minutes of the July 17, 2024, Governing Board meeting, as submitted.
6. Ratification of Purchase Orders, District Contracts and Check Register
Ratify Purchase Orders, District Contracts, and Warrants numbered 678078 through 678853.
7. Change Orders

Approve the Change Orders, as submitted.

8. Annual Agreements for Students with Special Needs Placed in Non-Public Schools
Authorize Clovis Unified School District to continue agreements with four non-public schools to address the unique educational needs of District students with special needs.
9. Annual Agreement for Student with Special Needs Placed in a Residential Treatment Center
Authorize Clovis Unified School District to continue the agreement with a residential treatment center to address the unique educational needs of a District student with special needs.

M. ACTION

In general (unless otherwise noted), these items were seen for Information at the prior Board meeting and will be voted on at this meeting. Agenda items titled "Annual" are recurring items submitted to the Board for approval yearly.

1. Agreement with ParentSquare, Inc.
Approve a three-year agreement with ParentSquare, Inc. for the provision of an integrated two-way communication platform for use at District schools and departments, as submitted.
2. Clovis Adult Education Courses 2024-25
Approve the Clovis Adult Education course offerings for the 2024-25 school year, as submitted.
3. Resolution No. 3998 – Annual Authorization of Inter-Fund Loans for Cash Flow Purposes
Adopt Resolution No. 3998 authorizing inter-fund loans for cash flow purposes, as submitted.
4. Resolution No. 4000 - Approving Conveyance of Public Utility Easement to Pacific Gas and Electric Company, APN 574-130-01T
Adopt Resolution No. 4000 approving the conveyance of a public utility easement to Pacific Gas and Electric Company, regarding APN 574-130-01T (TWO-THIRDS VOTE REQUIRED).
5. Resolution No. 4002 - Declaring Intention to Convey Easement to Fresno Metropolitan Flood Control District and Setting of Public Hearing, APNs 310-320-03ST, 310-320-05ST, 310-320-06ST, 310-050-38T
Adopt Resolution No. 4002 declaring the intention to convey an easement to Fresno Metropolitan Flood Control District (FMFCD) and set a Public Hearing for installation of a storm drain and other incidental purposes, APNs 310-320-03ST, 310-320-05ST, 310-320-06ST, 310-050-38T (TWO-THIRDS VOTE REQUIRED).

N. INFORMATION

Unless otherwise noted, these items are on the agenda to provide time for Board members to review prior to taking action on the items at the next Board meeting. Agenda items titled "Annual" are recurring items submitted to the Board for approval yearly.

1. Provisional Internship Permit
Approve the Provisional Internship Permit for the recommended teaching candidate, as submitted.
2. Section 125 Amendment to Flexible Benefit Plan
Approve an amendment to the District's Section 125 Flexible Benefit Plan, as submitted.
3. Triennial Agreement with CommonLit
Authorize the Superintendent or designee to enter into an agreement with CommonLit, a web-based toolkit, effective for a three-year period for school years 2024-25, 2025-26, and 2026-27.
4. Action Mentoring Program Agreement for 2024-25
Approve the mentoring agreement with Action Mentoring Program (AMP), as submitted.
5. Annual California School Boards Association Membership and Education Legal Alliance
Should the Governing Board desire to maintain its membership in the California School Boards Association (CSBA) for the 2024-25 school year, it will be necessary for the Board to approve the payment of dues in the amount of \$26,289. For membership in the Education Legal Alliance

(ELA), the Board will need to approve the payment in the amount of \$6,572.

6. Resolution No. 4003 - Approving Conveyance of Easement to Fresno Metropolitan Flood Control District, APNs 310-320-03ST, 310-320-05ST, 310-320-06ST, 310-050-38T
Adopt Resolution No. 4003 approving the conveyance of an easement to Fresno Metropolitan Flood Control District (FMFCD) for installation of a storm drain and other incidental purposes regarding APNs 310-320-03ST, 310-320-05ST, 310-320-06ST, 310-050-38T (TWO-THIRDS VOTE REQUIRED).
7. Resolution No. 4004 - Exemption to the Separation-from-Service Requirement for One Certificated Retiree
Adopt Resolution No. 4004, approving an exemption to the separation-from-service requirement for the 2024-25 school year (Education Code § 24214.5 or 26812).
8. Resolutions No. 4005 and 4006 – Exemptions to the Separation-from-Service Requirement for Two Classified Retirees
Adopt Resolutions No. 4005 and 4006 authorizing Clovis Unified School District to hire two CalPERS retirees prior to the 180-day post-retirement waiting period.
9. Award of Bid - Services
Recommendation for RFP 2998 - Charter Bus Services will be brought to the Governing Board for Action at a future date.

O. BOARD MEMBER REPORTS

P. ADJOURNMENT

CONTACT PERSON: Michael Johnston

FOR INFORMATION:

FOR ACTION: August 7, 2024

RECOMMENDATION:

Conduct a Public Hearing no earlier than 6:45 p.m. at 2770 East International Avenue, Fresno, 93730, regarding the conveyance of a public utility easement to Pacific Gas and Electric Company, APN 574-130-01T.

DISCUSSION:

Clovis Unified School District (District) owns the real property located between McKinley and Clinton avenues, and Fowler and Armstrong avenues in the City of Fresno, County of Fresno, State of California and designated as a portion of APN 574-130-01T (Property).

The District has undertaken a public works project to design and construct a new elementary school (Project) on the Property.

To connect gas, electricity, and other services to the Property, work is needed by Pacific Gas and Electric Company (PGE), a public utility, to excavate, construct, install and maintain certain facilities and equipment. PGE desires to acquire an easement over a portion of the Property for the purpose of excavating, constructing, reconstructing, replacing, removing, maintaining, inspecting, and using such facilities and equipment.

Pursuant to Education Code section 17557, the Board adopted on July 17, 2024, a resolution declaring its intention to convey the easement to PGE and set a public hearing for no earlier than 6:45 p.m. on August 7, 2024, on the question of making the conveyance. The meeting and public hearing will be held at Clovis North High School Lecture Hall, 2770 E. International Avenue, Fresno, CA 93730. During this meeting the Board will also be presented with a resolution to approve the conveyance of the easement to PGE.

FISCAL IMPACT/FUNDING SOURCE:

Not Applicable

ATTACHMENTS:

Description	Upload Date	Type
Public Notice	7/23/2024	Backup Material

REVISIONS:

NOTICE OF PUBLIC HEARING

CONVEYANCE OF UTILITY EASEMENT TO PACIFIC GAS AND ELECTRIC COMPANY, APN 574-130-01T FRESNO, CALIFORNIA

The Governing Board of the Clovis Unified School District (District) will **hold a public hearing on August 7, 2024, no earlier than 6:45 p.m.**, upon the question of making the dedication or conveyance of an utility easement to Pacific Gas and Electric Company on a portion of the real property located between McKinley Avenue and Clinton Avenue, and Fowler Avenue and Armstrong Avenue in the City of Fresno, County of Fresno, State of California and designated as APN 574-130-01T. The purpose of the conveyance of the easement is for the purpose of excavating, constructing, reconstructing, replacing, removing, maintaining, inspecting, and using such facilities and equipment.

The public hearing will be held at the following location:

Clovis North High School Lecture Hall
2770 E. International Avenue
Fresno, California 93730

CONTACT PERSON: Marc Hammack

FOR INFORMATION:

FOR ACTION: August 7, 2024

RECOMMENDATION:

Approve the Conference Requests, as submitted.

DISCUSSION:

Attached are the Conference Requests submitted for Board approval.

FISCAL IMPACT/FUNDING SOURCE:

N/A

ATTACHMENTS:

Description	Upload Date	Type
Conference Requests 8.7.2024	7/24/2024	Backup Material

REVISIONS:

**Clovis Unified School District
Conference Requests 8.7.2024**

Departure	Return	Attendee	Site/Dept	Conference Name	Conference Location	Purpose for Attending
8/11/2024	8/12/2024	Paula Vived	Special Education	Residential Treatment Center Visits	Spokane, WA	Residential treatment center visits for future student placements.
8/11/2024	8/12/2024	Danielle Hester	Special Education	Residential Treatment Center Visits	Spokane, WA	Residential treatment center visits for future student placements.
8/12/2024	8/13/2024	Paula Vived	Special Education	Residential Treatment Center Visits	Billings, MT	Residential treatment center visits for future student placements.
8/12/2024	8/13/2024	Danielle Hester	Special Education	Residential Treatment Center Visits	Billings, MT	Residential treatment center visits for future student placements.
8/13/2024	8/15/2024	Paula Vived	Special Education	Residential Treatment Center Visits	St. George, UT	Residential treatment center visits for future student placements.
8/13/2024	8/15/2024	Danielle Hester	Special Education	Residential Treatment Center Visits	St. George, UT	Residential treatment center visits for future student placements.
8/15/2024	8/18/2024	Jennifer O'Meara	Buchanan	Las Vegas Classic	Las Vegas, NV	Admin supervision during competition
8/22/2024	8/24/2024	Shawn Kilduff	Clovis East	Football Invitational	Salt Lake City, UT	Supervise and coach athletes during competition
8/22/2024	8/24/2024	Billy Erdman	Clovis East	Football Invitational	Salt Lake City, UT	Supervise and coach athletes during competition
8/22/2024	8/24/2024	Josh Lopez	Clovis East	Football Invitational	Salt Lake City, UT	Supervise and coach athletes during competition
8/22/2024	8/24/2024	John Capriola	Clovis East	Football Invitational	Salt Lake City, UT	Supervise and coach athletes during competition
8/22/2024	8/24/2024	Jovan Duka	Clovis East	Football Invitational	Salt Lake City, UT	Supervise and coach athletes during competition
8/22/2024	8/24/2024	Jake Howard	Clovis East	Football Invitational	Salt Lake City, UT	Supervise and coach athletes during competition
8/22/2024	8/24/2024	Tyrone Bishop	Clovis East	Football Invitational	Salt Lake City, UT	Supervise and coach athletes during competition
8/22/2024	8/24/2024	Kevin Robinson	Clovis East	Football Invitational	Salt Lake City, UT	Supervise and coach athletes during competition
8/22/2024	8/24/2024	Michael Preciado	Clovis East	Football Invitational	Salt Lake City, UT	Supervise and coach athletes during competition

**Clovis Unified School District
Conference Requests 8.7.2024**

8/22/2024	8/24/2024	Ivan Espiritu	Clovis East	Football Invitational	Salt Lake City, UT	Supervise and coach athletes during competition
8/22/2024	8/24/2024	Colby Hunter	Clovis East	Football Invitational	Salt Lake City, UT	Supervise and coach athletes during competition
8/22/2024	8/24/2024	James Humphrey	Clovis East	Football Invitational	Salt Lake City, UT	Supervise and coach athletes during competition
8/22/2024	8/24/2024	Demetrio Asparin	Clovis East	Football Invitational	Salt Lake City, UT	Supervise and coach athletes and maintain football equipment during competition
9/11/2024	9/15/2024	John Jay	Buchanan	Louisville Invitational Volleyball Tournament	Louisville, KY	Supervise and coach athletes during competition
9/11/2024	9/15/2024	Omar Hemaïdan	Buchanan	Louisville Invitational Volleyball Tournament	Louisville, KY	Admin supervision during competition
9/11/2024	9/15/2024	Johnathan Trevino	Buchanan	Louisville Invitational Volleyball Tournament	Louisville, KY	Supervise and coach athletes during competition
9/11/2024	9/15/2024	Justin Rita	Buchanan	Louisville Invitational Volleyball Tournament	Louisville, KY	Supervise and coach athletes during competition
9/23/2024	9/27/2024	Danielle Hester	Special Education	Student Assessment & Residential Treatment Center Visit	Salt Lake City, UT	Student assessment of current CUSD student and residential treatment center visit for future placements
9/23/2024	9/27/2024	Paula Vived	Special Education	Student Assessment & Residential Treatment Center Visit	Salt Lake City, UT	Student assessment of current CUSD student and residential treatment center visit for future placements.
9/23/2024	9/27/2024	Joanne Fiedler	Special Education	Student Assessment & Residential Treatment Center Visit	Salt Lake City, UT	Student assessment of current CUSD student and residential treatment center visit for future placements.
9/23/2024	9/27/2024	Whitney Swillis	Special Education	Student Assessment & Residential Treatment Center Visit	Salt Lake City, UT	Student assessment of current CUSD student and residential treatment center visit for future placements.
10/8/2024	10/12/2024	Angel Olavarria	Sierra Outdoor School	Care and Management of Captive Raptors	St. Paul, MN	Training in caring for and maintaining captive raptors for educational purposes

**Clovis Unified School District
Conference Requests 8.7.2024**

10/12/2024	10/19/2024	Michael Johnston	Admin Services	Cooperative Insurance for Public Agencies Conference	Kauai, HI	Attend CIPAs Annual Conference and Board of Director's meeting to meet the yearly requirements
12/4/2024	12/8/2024	Garrette Mantle	Clovis East	Honolulu Hawaii Girls Basketball Tournament	Honolulu, HI	Supervise and coach athletes during competition
12/4/2024	12/8/2024	Colin Graham	Clovis East	Honolulu Hawaii Girls Basketball Tournament	Honolulu, HI	Supervise and coach athletes during competition
12/4/2024	12/8/2024	Cassandra Capshew	Clovis East	Honolulu Hawaii Girls Basketball Tournament	Honolulu, HI	Admin supervision during competition

CONTACT PERSON: Marc Hammack

FOR INFORMATION:

FOR ACTION: August 7, 2024

RECOMMENDATION:

Approve the Fundraiser Requests, as submitted.

DISCUSSION:

Attached are the Fundraiser Requests submitted for Board approval.

FISCAL IMPACT/FUNDING SOURCE:

N/A

ATTACHMENTS:

Description	Upload Date	Type
Fundraiser Requests 8.7.2024	7/24/2024	Backup Material

REVISIONS:

**Clovis Unified School District
Fundraiser Requests 8.7.2024**

#	Site	Advisor	Start	End	Organization	Description	Vendor
9821	BHS	Troy Tirapelle	8/8/2024	6/30/2025	Athletics	Adult Dinners/Dance (ie. BBQs, crab feasts)	Costco, Save Mart Supermarkets, Mike's Grill
9813	Hirayama Elem	Laura Reynolds	8/19/2024	6/6/2025	PTC	Multicultural Event*	Country Fair Cinnamon Rolls, Jamba Juice, Dutch Bros. Coffee
9811	Hirayama Elem	Laura Reynolds	8/19/2024	6/6/2025	PTC	Spirit Wear/Spirit Packs	All American Sports USA
9810	Hirayama Elem	Laura Reynolds	8/19/2024	6/6/2025	PTC	Cookie Dough Sales*	Great American Fundraising
9809	Hirayama Elem	Laura Reynolds	8/19/2024	6/6/2025	PTC	Spirit Wear/Spirit Packs	Athletic Designs
9808	Hirayama Elem	Laura Reynolds	8/19/2024	6/6/2025	PTC	Membership Drive	None
9807	Dry Creek Elem	Aaron Cook, Holly Kampsen	8/8/2024	6/30/2025	PTC	Food Truck*	Weekend Dreams Burger & Grill
9806	Mickey Cox Elem	Karen Majchen	8/19/2024	6/6/2025	ASB	Candy Sales*	See's Candies, World's Finest Chocolates
9805	Mickey Cox Elem	Karen Majchen	8/19/2024	6/6/2025	ASB	Various "A-thons" (ie. Jog-A-Thons, Basketball Shoot-A-Thons)	Apex Fun Run
9804	Mickey Cox Elem	Karen Majchen	8/19/2024	6/6/2025	ASB	Restaurant Coupon/Ticket Sales	Crave Cookie, Papa Murphy's, Rocky Mountain Chocolate Factory, Bobby Salazar's, Gorilla Gurt, Nothing Bundt Cakes, Dippin' Dots
9803	Mickey Cox Elem	Karen Majchen	8/19/2024	6/6/2025	ASB	Coupon Books/Entertainment	Funding Your Goals, SaveAround Coupon Books, Believe Kids
9802	Mickey Cox Elem	Karen Majchen	8/19/2024	6/6/2025	ASB	Miscellaneous gift/catalog items sold*	Believe Kids
9801	Mickey Cox Elem	Allison Glaser	8/19/2024	6/6/2025	Yearbook	Yearbook Dedication/Ad Pages/Sales	Larson Brothers Photography
9800	Mickey Cox Elem	Emily Minton	8/19/2024	6/6/2025	Library	Book Fair	Scholastic Book Fair

*In compliance with Board Policy 3554.

**Clovis Unified School District
Fundraiser Requests 8.7.2024**

9799	Mickey Cox Elem	Michelle Houston	8/19/2024	6/6/2025	Pep and Cheer	Miscellaneous gift/catalog items sold*	Bosco Fundraising
9798	Mickey Cox Elem	Karen Majchen	8/19/2024	6/6/2025	PTC	Holiday Boutique	Dollar Tree, Gifts 'N Things
9796	Mickey Cox Elem	Karen Majchen	8/19/2024	6/6/2025	PTC	Family Fun Night*	California Jumping, All For Fun , United Skates Clovis, DEFY, Marco's Pizza, Me-n-Ed's, Little Caesars, Costco, Fresno Fun Jump Bounce House Rentals, No Surrender Laser Tag, Blackbeard's
9795	Mickey Cox Elem	Karen Majchen	8/19/2024	6/6/2025	PTC	Family Restaurant Night*	Chipotle Mexican Grill, Panda Express, Panera, Mountain Mike's Pizza, Mickey's Yogurt, In-N-Out Burger, Jersey Mike's Subs, Red Robin, Raising Cane's , Marco's Pizza
9794	Mickey Cox Elem	Karen Majchen	8/19/2024	6/6/2025	PTC	Holiday Grams*	Jo-Ann Fabrics & Crafts, Michael's, Sam's Club, Walmart, Costco, Dollar Tree, Oriental Trading Company, Smart & Final
9793	Mickey Cox Elem	Karen Majchen	8/19/2024	6/6/2025	PTC	Box Tops for Education	General Mills Box Tops
9792	Mickey Cox Elem	Karen Majchen	8/19/2024	6/6/2025	PTC	Membership Drive	Smart & Final, Vons, WinCo Foods, Walmart, Sam's Club, Save Mart Supermarkets, Costco
9791	Mickey Cox Elem	Karen Majchen	8/19/2024	6/6/2025	PTC	Movie Nights*	Little Caesars, Costco, Sam's Club, Walmart, WinCo Foods, Smart & Final
9790	Mickey Cox Elem	Karen Majchen	8/19/2024	6/6/2025	PTC	Parent Child Night	Smiley Photo Booth Rental, 360 Photo Booth Rental, United Skates Clovis, Smart & Final, Walmart, Sam's Club, Blackbeard's, Costco, Larson Brothers Photography

*In compliance with Board Policy 3554.

**Clovis Unified School District
Fundraiser Requests 8.7.2024**

9789	Mickey Cox Elem	Karen Majchen	8/19/2024	6/6/2025	PTC	Spirit Wear/Spirit Packs	Harcourt Outlines, Artworkz, First String Sports, Good Cotton Print, Spirit Gear Direct, All Signs, Alpha Custom T-Shirt, EmbroidMe, The Print District, Alpha Graphics
9788	Mickey Cox Elem	Karen Majchen	8/19/2024	6/6/2025	PTC	Snack Bar Sales*	Smart & Final, WinCo Foods, Sam's Club, Walmart, Costco
9787	Mickey Cox Elem	Karen Majchen	8/19/2024	6/6/2025	PTC	Muffins with Mom*	Costco, Save Mart Supermarkets, Walmart, WinCo Foods, Judy's Donuts, Bullard Donut and Bakery, Vons, Liv's Donuts
9786	Mickey Cox Elem	Karen Majchen	8/19/2024	6/6/2025	PTC	Restaurant Coupon/Ticket Sales	Nothing Bundt Cakes, Crave Cookie, Crumbl Cookies, Spirit Gear Direct
9785	Mickey Cox Elem	Karen Majchen	8/19/2024	6/6/2025	PTC	Carnivals*	Dippin' Dots, Fresno Fun Jump Bounce House Rentals, Kona Ice, All For Fun , Olde Tyme Kettle Korn, Fiesta Party Rentals , Sunbelt Rentals, Best Party Rentals, Bounce House Bonanza, All Aboard Train Rentals
9781	Woods Elem	Cecelia Dansby	8/8/2024	6/30/2025	ASB	Popcorn Sales*	Believe Kids
9780	Fancher Creek Elem	Carisa Cordova	8/8/2024	5/30/2025	Athletics	Donations to Program	None
9779	Fancher Creek Elem	Isabella Naranjo	8/12/2024	8/16/2024	Folklorico	Back to School Night*	WinCo Foods, Save Mart Supermarkets, Costco
9778	Fancher Creek Elem	Carisa Cordova	8/19/2024	6/6/2025	Student Council	Father Daughter Dance*	Oriental Trading Company, Costco, Amazon, Smart & Final
9776	District Office	Principals	8/8/2024	6/6/2025	District Wide	Donations for Charitable Organizations	Marjaree Mason Center, Pennies for Patients, Poverello House, Animal Rescue, Fresno Rescue Mission, Ronald McDonald House Charities, Stand Up 2 Cancer, Susan G. Komen, Coats for Kids, UNICEF, Caps for Kids, Leukemia & Lymphoma Society, St Baldrick's

*In compliance with Board Policy 3554.

**Clovis Unified School District
Fundraiser Requests 8.7.2024**

9774	Kastner Inter	Stephanie Barcellos	8/8/2024	6/6/2025	Aquatics	Movie Nights*	Smart & Final, Save Mart Supermarkets, Costco
9773	Gettysburg Elem	Katie Scalzo	8/8/2024	6/6/2025	PTC	Car Show*	Guadalajara Restaurant, Dippin' Dots, Bulldog Burger Bistro, Marco's Pizza, Bato Baos, Bowls, & Buns, Hot Dog on a Stick, Smart & Final, Olde Tyme Kettle Korn
9772	Maple Creek Elem	Gina Kismet	8/8/2024	6/6/2025	PTC	Food Truck*	Sweet Baby Cakes, Tia Mo's Outdoor Kitchen
9771	REC	Shelby Parker	8/8/2024	6/30/2025	AVID	Student Planner Sales	CUSD Graphic Arts
9770	REC	Keila Tolladay	8/8/2024	6/30/2025	Girls Golf	Miscellaneous gift/catalog items sold*	Dad's Cookies , Crave Cookie, Crumbl Cookies, Nothing Bundt Cakes
9769	Kastner Inter	Jewell Robinson	8/8/2024	6/6/2025	Pep and Cheer	Pep and Cheer Activity	Rush Advertising, Performance Wear
9768	Kastner Inter	Jewell Robinson	8/8/2024	6/6/2025	Pep and Cheer	Miscellaneous gift/catalog items sold*	Signature Chocolates Fundraising
9767	Kastner Inter	Jewell Robinson	8/8/2024	6/6/2025	Pep and Cheer	Miscellaneous gift/catalog items sold*	Double Good Popcorn
9766	Kastner Inter	Jewell Robinson	8/8/2024	6/6/2025	Pep and Cheer	Showcase (Fashion, Drama, Dance, etc.)	None
9765	Kastner Inter	Jewell Robinson	8/8/2024	6/6/2025	Pep and Cheer	Family Restaurant Night*	Pelican Snow Cones, Panda Express, McDonald's, Chipotle Mexican Grill, Mountain Mike's Pizza
9764	Kastner Inter	Jewell Robinson	8/8/2024	6/6/2025	Pep and Cheer	Showcase (Fashion, Drama, Dance, etc.)	None
9763	Kastner Inter	Jewell Robinson	8/8/2024	6/6/2025	Pep and Cheer	Miscellaneous gift/catalog items sold*	Believe Kids
9762	Kastner Inter	Jewell Robinson	8/8/2024	6/6/2025	Pep and Cheer	Spirit Wear/Spirit Packs	Performance Wear, Rush Advertising

*In compliance with Board Policy 3554.

**Clovis Unified School District
Fundraiser Requests 8.7.2024**

9761	Kastner Inter	Jewell Robinson	8/8/2024	6/6/2025	Pep and Cheer	Bingo Night*	Fort Washington Country Club
9760	Kastner Inter	Jewell Robinson	8/8/2024	6/27/2025	Pep and Cheer	Spirit Wear/Spirit Packs	Performance Wear, Rush Advertising
9759	Riverview Elem	Kaitlyn Vargas	8/8/2024	6/6/2025	ASB	Team T-Shirt Sponsors	Spirit Gear Direct
9758	Sierra Vista Elem	Jennifer Thao	8/8/2024	6/6/2025	PTC	Holiday Boutique	Penguin Patch Holiday Shop
9757	Sierra Vista Elem	Jennifer Thao	8/8/2024	6/6/2025	PTC	Holiday Grams*	Oriental Trading Company, FoodMaxx, Dollar Tree, Costco, Michael's, Walmart, Food 4 Less, Save Mart Supermarkets, Sprouts, Office Depot Office Max, Target, Starbucks, Vons, Smart & Final
9756	Sierra Vista Elem	Jennifer Thao	8/8/2024	6/6/2025	PTC	Membership Drive	Smart & Final, Square Heart Shops, Target, Office Depot Office Max, Food 4 Less, Michael's, Costco, Dollar Tree, FoodMaxx, Oriental Trading Company
9755	Sierra Vista Elem	Jennifer Thao	8/8/2024	6/6/2025	PTC	Mother Son Dance*	Dominion's Pizza, Save Mart Supermarkets, Food 4 Less, Walmart, Michael's, Me-n-Ed's, Oriental Trading Company, Little Caesars, Larson Brothers Photography, Costco, FoodMaxx, Dollar Tree, Smart & Final, Target
9754	Sierra Vista Elem	Yee Thao	8/8/2024	6/6/2025	ASB	Yearbook Dedication/Ad Pages/Sales	Larson Brothers Photography
9753	Sierra Vista Elem	Michael Williamson	8/8/2024	6/6/2025	ASB	Box Tops for Education	General Mills Box Tops
9752	Sierra Vista Elem	Rachel Fern	8/8/2024	6/6/2025	ASB	Book Fair	Scholastic Book Fair
9751	Sierra Vista Elem	Michael Williamson	8/8/2024	6/6/2025	ASB	Spirit Wear/Spirit Packs	Spirit Gear Direct, Artworkz

*In compliance with Board Policy 3554.

**Clovis Unified School District
Fundraiser Requests 8.7.2024**

9750	Sierra Vista Elem	Jennifer Thao	8/8/2024	6/6/2025	PTC	Family Restaurant Night*	In-N-Out Burger, Carl's Jr., Buffalo Wild Wings, Jamba Juice, Chipotle Mexican Grill, McDonald's, Panda Express, Little Caesars, Krispy Kreme, El Pollo Loco, Crumbl Cookies, MOD Pizza, Red Robin, Starbucks
9749	Sierra Vista Elem	Jennifer Thao	8/8/2024	6/6/2025	ASB	Family Restaurant Night*	Red Robin, Crumbl Cookies, El Pollo Loco, Krispy Kreme, Little Caesars, Panda Express, McDonald's, Chipotle Mexican Grill, Jamba Juice, Carl's Jr., In-N-Out Burger
9748	Gettysburg Elem	Katie Scalzo	8/8/2024	6/6/2025	ASB	Food Truck*	Dippin' Dots, Kona Ice, Guadalajara Restaurant, Los Toritos Taco Truck, Hot Dog on a Stick, Marco's Pizza, Bato Baos, Bowls, & Buns, Bulldog Burger Bistro
9747	Gettysburg Elem	Katie Scalzo	8/8/2024	6/6/2025	PTC	Food Truck*	Bulldog Burger Bistro, Hot Dog on a Stick, Bato Baos, Bowls, & Buns, Los Toritos Taco Truck, Dippin' Dots, Kona Ice, Guadalajara Restaurant
9562	Fancher Creek Elem	Carisa Cordova	8/19/2024	6/6/2025	ASB	Buddy Pictures	Larson Brothers Photography
9560	Fancher Creek Elem	Courtney Burnett	8/19/2024	6/6/2025	ASB	Online Food Sales*	Double Good Popcorn
9559	Fancher Creek Elem	Carisa Cordova	8/8/2024	6/6/2025	PTC	Online Donations	Snap! Raise Fundraising
9558	Fancher Creek Elem	Carisa Cordova	8/19/2024	6/6/2025	ASB	Student Photos/Posters	Larson Brothers Photography
9556	Fancher Creek Elem	Carisa Cordova	8/19/2024	6/6/2025	Human Relation Committee	Multicultural Event*	Costco, Save Mart Supermarkets, Smart & Final
9553	Fancher Creek Elem	Yvonne Foley	8/19/2024	6/6/2025	ASB	Book Fair	Scholastic Book Fair
9550	Fancher Creek Elem	Carisa Cordova	8/19/2024	6/6/2025	Pep and Cheer	Candy Sales*	Chocolate Wishes
9549	Fancher Creek Elem	Debbie Nisbett	8/19/2024	6/6/2025	Classroom	Donuts with Dad*	WinCo Foods, Walmart, Save Mart Supermarkets

*In compliance with Board Policy 3554.

**Clovis Unified School District
Fundraiser Requests 8.7.2024**

9548	Fancher Creek Elem	Kathleen Deluca	8/19/2024	6/6/2025	Athletics	Mother Son Dance*	Smart & Final, Vons, WinCo Foods, Oriental Trading Company, Costco
9545	Fancher Creek Elem	Carisa Cordova	8/19/2024	6/6/2025	6th Grade	Candy Sales*	Believe Kids
9544	Miramonte Elem	Brittany Salley	8/8/2024	6/30/2025	6th Grade	Miscellaneous gift/catalog items sold*	Crave Cookie
9522	Fancher Creek Elem	Eric Horn	8/19/2024	6/6/2025	5th Grade	Family Restaurant Night*	Mountain Mike's Pizza
9515	Fancher Creek Elem	Carisa Cordova	8/19/2024	6/6/2025	PTC	Holiday Boutique	Oriental Trading Company, Dollar Tree
9513	Fancher Creek Elem	Carisa Cordova	8/19/2024	6/6/2025	PTC	Pancake Breakfast *	Smart & Final, Costco
9510	Fancher Creek Elem	Sarah Bugayong	8/19/2024	5/30/2025	PTC	Movie Nights*	Kona Ice, Me-n-Ed's, 559 Tacos, Lolo Hawaiian Shaved Ice, Los Mexicanos Frutas Y Antojitos, Hot Dog on a Stick, Bob's & Brew's Food Truck, Rollin Donuts, Dad's Cookies
9500	Fancher Creek Elem	Carisa Cordova	8/19/2024	6/6/2025	Kindergarten	Candy Sales*	See's Candies
9489	Fancher Creek Elem	Chintana Thatsanaphone	8/19/2024	6/6/2025	2nd Grade	Goodies with Grandparents*	Smart & Final, WinCo Foods, Costco
9483	Fancher Creek Elem	Sonia Tinoco	8/19/2024	6/6/2025	Student Council	Event Food Sales *	Little Caesars, Oriental Trading Company

*In compliance with Board Policy 3554.

CONTACT PERSON: Marc Hammack

FOR INFORMATION:

FOR ACTION: August 7, 2024

RECOMMENDATION:

Approve the Student Trip Requests, as submitted.

DISCUSSION:

Attached are the Student Trip Requests submitted for Board approval.

FISCAL IMPACT/FUNDING SOURCE:

N/A

ATTACHMENTS:

Description	Upload Date	Type
Student Trip Requests 8.7.2024	7/24/2024	Backup Material

REVISIONS:

**Clovis Unified School District
Student Trip Requests 8.7.2024**

Trip ID	Trip Name	Start Time	Return Time	Account:	Destination	Passengers
93339	CWHS Girls Tennis	08/22/2024 07:00 AM	08/23/2024 10:00 PM	CWH/ATH-0500-Van	Bakersfield, CA	14
Trip ID	Trip Name	Start Time	Return Time	Account:	Destination	Passengers
93335	CWHS Boys Water Polo	08/23/2024 06:00 AM	08/24/2024 10:00 PM	CWH/ATH-FDN-Van-BrdApp	Arroyo Grande, CA	14
Trip ID	Trip Name	Start Time	Return Time	Account:	Destination	Passengers
93336	CWHS Boys Water Polo	08/23/2024 06:00 AM	08/24/2024 10:00 PM	CWH/ATH-FDN-Van-BrdApp	Arroyo Grande, CA	14
Trip ID	Trip Name	Start Time	Return Time	Account:	Destination	Passengers
93290	CCUR CW Boys Basketball	09/06/2024 06:00 AM	09/09/2024 10:00 PM	CCUR-CWHS-Van-BrdApp	La Jolla, CA	21
Trip ID	Trip Name	Start Time	Return Time	Account:	Destination	Passengers
93338	CWHS Boys Water Polo	09/06/2024 06:00 AM	09/07/2024 10:00 PM	CWH/ATH-FDN-Van-BrdApp	Menlo Park, CA	14
Trip ID	Trip Name	Start Time	Return Time	Account:	Destination	Passengers
93365	CAGD Clovis Academy Gymnastics	09/06/2024 06:00 AM	09/08/2024 11:00 PM	CCUR-NONE-BrdApp	Rancho Cordova, CA	45
Trip ID	Trip Name	Start Time	Return Time	Account:	Destination	Passengers
93340	CWHS Girls Tennis	09/10/2024 07:00 AM	09/11/2024 10:00 PM	CWH/ATH-0500-Van	Atascadero, CA	14
Trip ID	Trip Name	Start Time	Return Time	Account:	Destination	Passengers
93291	CCUR CW Boys Basketball	09/20/2024 06:00 AM	09/23/2024 10:00 PM	CCUR-CWHS-Van-BrdApp	Anaheim, CA	21
Trip ID	Trip Name	Start Time	Return Time	Account:	Destination	Passengers
93337	CWHS Boys Water Polo	09/20/2024 06:00 AM	09/21/2024 10:00 PM	CWH/ATH-FDN-Van-BrdApp	Granite Bay, CA	14
Trip ID	Trip Name	Start Time	Return Time	Account:	Destination	Passengers
93364	CAGD Clovis Academy Gymnastics	09/27/2024 06:00 AM	09/29/2024 11:00 PM	CCUR-NONE-BrdApp	Stockton, CA	45
Trip ID	Trip Name	Start Time	Return Time	Account:	Destination	Passengers
93361	CAGD Clovis Academy Gymnastics	10/11/2024 06:00 AM	10/13/2024 11:00 PM	CCUR-NONE-BrdApp	Stockton, CA	45
Trip ID	Trip Name	Start Time	Return Time	Account:	Destination	Passengers
93363	CAGD Clovis Academy Gymnastics	11/08/2024 06:00 AM	11/10/2024 11:00 PM	CCUR-NONE-BrdApp	Rancho Cordova, CA	45
Trip ID	Trip Name	Start Time	Return Time	Account:	Destination	Passengers
93362	CAGD Clovis Academy Gymnastics	11/22/2024 06:00 AM	11/24/2024 11:00 PM	CCUR-NONE-BrdApp	San Mateo, CA	45
Trip ID	Trip Name	Start Time	Return Time	Account:	Destination	Passengers
93284	CEHS Girls Basketball	12/04/2024 06:00 AM	12/08/2024 11:00 PM	CEH-NONE-BrdApp	Honolulu, HI	14
Trip ID	Trip Name	Start Time	Return Time	Account:	Destination	Passengers
93332	CWHS Girls Basketball	12/19/2024 06:00 AM	12/23/2024 10:00 PM	CWH-NONE-BrdApp	Portland, OR	16
Trip ID	Trip Name	Start Time	Return Time	Account:	Destination	Passengers
93333	CWHS Girls Basketball	12/26/2024 06:00 AM	12/31/2024 10:00 PM	CWH-NONE-BrdApp	Tampa, FL	16
Trip ID	Trip Name	Start Time	Return Time	Account:	Destination	Passengers
93334	CWHS Girls Basketball	01/02/2025 06:00 AM	01/05/2025 10:00 PM	CWH-NONE-BrdApp	Denver, CO	16
Trip ID	Trip Name	Start Time	Return Time	Account:	Destination	Passengers
93270	Liberty History Day	04/18/2025 12:00 PM	04/20/2025 04:00 PM	LIB-NONE-BrdApp	Sacramento, CA	3

Wednesday, July 24, 2024 08:06 AM

CONTACT PERSON: Marc Hammack

FOR INFORMATION:

FOR ACTION: August 7, 2024

RECOMMENDATION:

Approve the Voluntary Community Recreation Programs, as submitted.

DISCUSSION:

The Clovis Community Sports and Recreation Department provides and operates noneducational, athletic and recreation programs and activities for the access and enjoyment of Clovis and surrounding communities. Such noneducational, recreational programs and activities are not part of the District's curricular, extracurricular, or co-curricular educational programs, and are entirely separate and distinct from the District's educational program. The Department's recreational offerings are available to all age-appropriate participants in Clovis, Fresno and surrounding communities, whether or not such participants are enrolled in the District's educational program, and students enrolled in the District's educational program are never required to participate in the Department's noneducational, recreational programs or activities.

The proposed costs listed below are to attend the camp/clinic and may not include additional items such as spirit packs, shirts, jerseys, etc. The additional items will be provided at cost with no profit for the program. All additional items will be specifically identified in the flyers to the community.

Clovis Community Sports and Recreation Department
Intermediate Water Polo Camp
Kastner Intermediate School
Date: August 8 – 23, 2024
Grade: 6-8
Cost: \$30.00 per participant

Clovis Community Sports and Recreation Department
Summer Boys and Girls Volleyball Camp
Buchanan High School
Date: August 8 – 9, 2024
Grade: 2-5
Cost: \$25.00 per participant

Clovis Community Sports and Recreation Department
Wolf Den Elementary Wrestling Club
Clovis East High School
Date: October 28, 2024 – January 20, 2025

Grade: 4-6
Cost: \$150.00 per participant

Clovis Community Sports and Recreation Department
Advanced Youth Wrestling Camp
Clovis East High School
Date: November 3 – 7, 2024
Grade: 4-6
Cost: \$35.00 per participant

Clovis Community Sports and Recreation Department
Thanksgiving Elementary Wrestling Camp
Clovis East High School
Date: November 24 – 26, 2024
Grade: 4-6
Cost: \$35.00 per participant

Clovis Community Sports and Recreation Department
Winter Monsters Elementary Wrestling Camp
Clovis East High School
Date: December 16 – 19, 2024
Grade: 4-6
Cost: \$35.00 per participant

Clovis Community Sports and Recreation Department
Wolfpack Football Spring Camp - Varsity
Clovis East High School
Date: January 1 – May 30, 2025
Grade: 9-12
Cost: \$0

Clovis Community Sports and Recreation Department
Wolfpack Football Jr. High/Frosh/JV Spring Camp
Clovis East High School
Date: March 1 – May 30, 2025
Grade: 7-10
Cost: \$0

Clovis Community Sports and Recreation Department
Elite Pack Wrestling Club
Clovis East High School
Date: March 3 – August 18, 2025
Grade: 9-12
Cost: \$150.00 per participant

Clovis Community Sports and Recreation Department
Wolf Den Wrestling Club

Clovis East High School
Date: March 3 – August 19, 2025
Grade: 4-12
Cost: \$0

Clovis Community Sports and Recreation Department
Wolfpack Football Pre-Season Camp
Clovis East High School
Date: May 1 – August 1, 2025
Grade: 9-12
Cost: \$0

Clovis Community Sports and Recreation Department
Wolfpack Football Summer Camp
Clovis East High School
Date: July 1 – August 15, 2025
Grade: 9-12
Cost: \$0

FISCAL IMPACT/FUNDING SOURCE:

No fiscal impact.

REVISIONS:

Title: July 17, 2024, Governing Board Meeting Minutes

CONTACT PERSON: Corrine Folmer

FOR INFORMATION:

FOR ACTION: August 7, 2024

RECOMMENDATION:

Approve the minutes of the July 17, 2024, Governing Board meeting, as submitted.

DISCUSSION:

FISCAL IMPACT/FUNDING SOURCE:

N/A

ATTACHMENTS:

Description	Upload Date	Type
Minutes 7.17.2024	7/29/2024	Backup Material

REVISIONS:



GOVERNING BOARD MEETING

MINUTES

July 17, 2024

***Professional Development Building, Boardroom
1680 David E. Cook Way, Clovis, California***

5:30 P.M. – CLOSED SESSION

6:30 P.M. – PUBLIC SESSION

Members of the public who wish to provide public comments must do so in-person during the board meeting. **Please complete and submit a Public Comment Form before the start of the Public Session on the day of the meeting.** The Public Comment Form is available outside the board meeting room on the day of the meeting. During the meeting, speakers who have requested to address the Board will be called to do so. Comments on items that are on the agenda are to be made when the item is called by the Board President. Comments on matters that are not on the agenda are to be made during the Public Presentations. Pursuant to Board Bylaw No. 9323, each speaker generally has up to 2 minutes to speak. The Board President may adjust the time allotted for each speaker and limit the total time for public comment. No speaker may yield his or her time to another speaker. Each regular board meeting will be video recorded by the District, the recording of which will be made accessible to the public within 48 hours of the board meeting at:

<https://www.cusd.com/BoardMeetingsAgendasArchives.aspx>

Regular Meeting AGENDA

*Additional information regarding this agenda may be viewed through the District's website at
<https://www.cusd.com/BoardMeetingsAgendasArchives.aspx>*

In compliance with the Americans with Disabilities Act, if you need special assistance to access the Board meeting room or to otherwise participate at this meeting, including auxiliary aids or services, please contact the Superintendent's Office at 327-9100. Notification at least 48 hours prior to the meeting will enable the District to make reasonable arrangements to ensure accessibility to the Board meeting.

Public records relating to an open session agenda item of a regular meeting that are distributed within 72 hours prior to the meeting will be available for public inspection at the District Office, 1450 Herndon Avenue, Clovis, California.

An invocation may be held prior to the start of the Board meeting. Attendance during and participation in the invocation are optional and voluntary. No students, parents, members of the public, Board members, student board member, or employees are required to attend or participate in the invocation.

INVOCATION

Board Member Tiffany Stoker Madsen led the invocation.

A. CALL TO ORDER

President Hugh Awtrey called the Governing Board meeting to order at 5:32 p.m.

B. ROLL CALL

Board Members Present:

Hugh Awtrey, President
Yolanda Moore, Vice President (arrived 5:35 p.m.)
Clinton Olivier, Clerk
David DeFrank, Member
Tiffany Stoker Madsen, Member

Board Members Absent:

Deena Combs-Flores, Member
Steven Fogg, M.D., Member

District Administration Present:

Corrine Folmer, Ed.D., Superintendent
Norm Anderson, Deputy Superintendent
Marc Hammack, Ed.D., Associate Superintendent
Barry Jager, Associate Superintendent
Michael Johnston, Associate Superintendent
Shawn VanWagenen, General Counsel
Maiya Yang, General Counsel

C. ADOPTION OF AGENDA

Adopted the July 17, 2024, Governing Board meeting agenda, as submitted. Yolanda Moore was not present for this vote.

Motion: Approve, Moved By Board Member David DeFrank, Seconded by Board Member Clinton Olivier. Passed. 4-0. Board Members voting Ayes: Awtrey, DeFrank, Olivier, Stoker Madsen Board Members voting Absent: Combs-Flores, Fogg, Moore

D. CLOSED SESSION

The Board adjourned to Closed Session at 5:33 p.m. to discuss the following items:

1. CONFERENCE WITH LEGAL COUNSEL – ANTICIPATED LITIGATION – Significant Exposure to Litigation (Pursuant to Subdivision (d)(2) of Gov't. Code §54956.9) – 3 cases
2. CONFERENCE WITH LEGAL COUNSEL – EXISTING LITIGATION (Gov't Code §54956.9(d)) - Cases No. SA-CE-3040-E, SA-CE-3047-E, SA-CE-3051-E, OAH Case No. 2024050785, OAH Case No. 2024050463, OAH Case No. 2024041077, OAH Case No. 2024060139
3. CONFERENCE WITH LABOR NEGOTIATORS (Education Code §54957.6) Agency Negotiator – Corrine Folmer, Ed.D., Supt. Negotiating Parties – Contracted Emps., Cert. Mgmt., Cert. Teachers, Class. Emps., Class. Mgmt. and Ops. Unit (Represented by CSEA Clovis Chapter 250)
4. APPOINTMENT/EMPLOYMENT OF DEPUTY PRINCIPAL, CLOVIS WEST HIGH SCHOOL (Gov't Code §54957)
5. APPOINTMENT/EMPLOYMENT OF INDIVIDUALS IN POSITIONS LISTED IN BOARD POLICY EXHIBITS NO. 4151.10, 4251.10, 4351.10, 4151.21, 4151.22, 4151.23, AND 4251.10 (Gov't. Code §54957)
6. PUBLIC EMPLOYEE DISCIPLINE/DISMISSAL/RELEASE/SUSPENSION (Gov't. Code

7. STUDENT DISCIPLINE AND OTHER CONFIDENTIAL STUDENT MATTERS (Education Code §48900 et seq. and §35146)

E. RECONVENE FOR PUBLIC SESSION

President Hugh Awtrey reconvened the public meeting at 6:30 p.m.

F. RECOGNITION OF VISITORS

President Hugh Awtrey welcomed meeting attendees present.

G. PLEDGE OF ALLEGIANCE

President Hugh Awtrey led the Board members and meeting attendees in the Pledge of Allegiance.

H. CLOSED SESSION MOTIONS

Approved the appointment of current Learning Director of Athletics at Clovis West High School Matt Loggins to the open position of Deputy Principal at Clovis West High School.

Motion: Approve, Moved By Board Member Clinton Olivier, Seconded by Board Member Tiffany Stoker Madsen. Passed. 5-0. Board Members voting Ayes: Awtrey, DeFrank, Moore, Olivier, Stoker Madsen. Board Members voting Absent: Combs-Flores, Fogg.

Approved routine Personnel Matters, as submitted.

Motion: Approve, Moved By Board Member Tiffany Stoker Madsen, Seconded by Board Member Clinton Olivier. Passed. 5-0. Board Members voting Ayes: Awtrey, DeFrank, Moore, Olivier, Stoker Madsen. Board Members voting Absent: Combs-Flores, Fogg.

I. SUPERINTENDENT'S REPORT

Superintendent Corrine Folmer, Ed.D., shared her report with the members of the Governing Board regarding recent news, events and achievements from across the District.

J. PUBLIC PRESENTATIONS

This time is reserved for individuals who may wish to address the Board regarding a matter that is not included on the agenda. Please note that because the items brought up by the public during this time are not on the agenda, the Governing Board may not discuss or act upon such items.

K. STAFF REPORTS

1. Presentation of the Logos for the Terry P. Bradley Educational Center Schools

Assistant Superintendent for the Clovis South Area Stephanie Hanks, Ed.D., and Terry P. Bradley Educational Center Principal Sonia Torossian, Ed.D., presented the new logos for Clovis South High School and Phillip V. Sanchez Intermediate School to members of the Governing Board.

2. Annual Child Development Preschool Program Self-Evaluation (Written)

A written report on the District's Child Development Preschool program was provided for review by members of the CUSD Governing Board.

3. Annual Child Development Expanded Learning Club Program Self-Evaluation (Written)

A written report on the District's Child Development Expanded Learning Club (ELC) program was provided for review by members of the CUSD Governing Board.

L. CONSENT

1. Conference Requests

Approved the Conference Requests, as submitted.

Motion: Approve, Moved By Board Member Clinton Olivier, Seconded by Board Member Yolanda Moore. Passed. 5-0. Board Members voting Ayes: Awtrey, DeFrank, Moore, Olivier, Stoker Madsen. Board Members voting Absent: Combs-Flores, Fogg.

2. Fundraiser Requests

Approved the Fundraiser Requests, as submitted.

Motion: Approve, Moved By Board Member Clinton Olivier, Seconded by Board Member Yolanda Moore. Passed. 5-0. Board Members voting Ayes: Awtrey, DeFrank, Moore, Olivier, Stoker Madsen. Board Members voting Absent: Combs-Flores, Fogg.

3. Student Trip Requests

Approved the Student Trip Requests, as submitted.

Motion: Approve, Moved By Board Member Clinton Olivier, Seconded by Board Member Yolanda Moore. Passed. 5-0. Board Members voting Ayes: Awtrey, DeFrank, Moore, Olivier, Stoker Madsen. Board Members voting Absent: Combs-Flores, Fogg.

4. Voluntary Community Recreation Programs

Approved the Voluntary Community Recreation programs, as submitted.

Motion: Approve, Moved By Board Member Clinton Olivier, Seconded by Board Member Yolanda Moore. Passed. 5-0. Board Members voting Ayes: Awtrey, DeFrank, Moore, Olivier, Stoker Madsen. Board Members voting Absent: Combs-Flores, Fogg.

5. June 12, 2024, Governing Board Meeting Minutes

Approved the minutes of the June 12, 2024, Governing Board meeting, as submitted.

Motion: Approve, Moved By Board Member Clinton Olivier, Seconded by Board Member Yolanda Moore. Passed. 5-0. Board Members voting Ayes: Awtrey, DeFrank, Moore, Olivier, Stoker Madsen. Board Members voting Absent: Combs-Flores, Fogg.

6. June 24, 2024, Governing Board Special Meeting Minutes

Approved the minutes of the June 24, 2024, Governing Board special meeting, as submitted.

Motion: Approve, Moved By Board Member Clinton Olivier, Seconded by Board Member Yolanda Moore. Passed. 5-0. Board Members voting Ayes: Awtrey, DeFrank, Moore, Olivier, Stoker Madsen. Board Members voting Absent: Combs-Flores, Fogg.

7. Ratification of Purchase Orders, District Contracts and Check Register

Ratified Purchase Orders, District Contracts, and Warrants numbered 677438 through 678077.

Motion: Approve, Moved By Board Member Clinton Olivier, Seconded by Board Member Yolanda Moore. Passed. 5-0. Board Members voting Ayes: Awtrey, DeFrank, Moore, Olivier, Stoker Madsen. Board Members voting Absent: Combs-Flores, Fogg.

8. Change Orders

Approved the Change Orders, as submitted.

Motion: Approve, Moved By Board Member Clinton Olivier, Seconded by Board Member Yolanda Moore. Passed. 5-0. Board Members voting Ayes: Awtrey, DeFrank, Moore, Olivier, Stoker Madsen. Board Members voting Absent: Combs-Flores, Fogg.

9. Annual Agreement with Comprehensive Youth Services

Authorized the Superintendent or designee to enter into an agreement with Comprehensive

Youth Services (CYS) to provide support services for the Parent Resource Centers in the Alternative Education, Buchanan, Clovis, Clovis East, Clovis North, Clovis South, and Clovis West areas during the 2024-25 school year, as submitted.

Motion: Approve, Moved By Board Member Clinton Olivier, Seconded by Board Member Yolanda Moore. Passed. 5-0. Board Members voting Ayes: Awtrey, DeFrank, Moore, Olivier, Stoker Madsen. Board Members voting Absent: Combs-Flores, Fogg.

- 10.** Annual Agreement with WestEd for California Teaching Pyramid Framework Training to Support the Universal Pre-kindergarten Grant

Approved the agreement with WestEd for California Teaching Pyramid Framework Training to support the Universal Pre-kindergarten Grant.

Motion: Approve, Moved By Board Member Clinton Olivier, Seconded by Board Member Yolanda Moore. Passed. 5-0. Board Members voting Ayes: Awtrey, DeFrank, Moore, Olivier, Stoker Madsen. Board Members voting Absent: Combs-Flores, Fogg.

- 11.** Annual Memorandum of Understanding with J&D Mind Builders, Bricks4Kidz

Approved the Memorandum of Understanding with J&D Mind Builders, Bricks4Kidz effective August 1, 2024, through June 30, 2025, to provide enrichment experiences to all students who participate in the Expanded Learning Club.

Motion: Approve, Moved By Board Member Clinton Olivier, Seconded by Board Member Yolanda Moore. Passed. 5-0. Board Members voting Ayes: Awtrey, DeFrank, Moore, Olivier, Stoker Madsen. Board Members voting Absent: Combs-Flores, Fogg.

- 12.** Annual Agreement with JDT Consultants

Authorized the Superintendent or designee to enter into an annual agreement with JDT Consultants, a non-public agency, to provide educationally related Therapeutic Behavior Services to eligible students with special needs as described in their Individualized Education Programs.

Motion: Approve, Moved By Board Member Clinton Olivier, Seconded by Board Member Yolanda Moore. Passed. 5-0. Board Members voting Ayes: Awtrey, DeFrank, Moore, Olivier, Stoker Madsen. Board Members voting Absent: Combs-Flores, Fogg.

- 13.** Annual Agreement with Behavioral Intervention, Coaching and Consulting Central California, LLC

Authorized the Superintendent or designee to enter into an agreement with Behavioral Intervention, Coaching and Consulting Central California, Limited Liability Company to provide educationally related, applied behavioral analysis and behavior intervention services to eligible Special Education students as described in their Individualized Education Programs.

Motion: Approve, Moved By Board Member Clinton Olivier, Seconded by Board Member Yolanda Moore. Passed. 5-0. Board Members voting Ayes: Awtrey, DeFrank, Moore, Olivier, Stoker Madsen. Board Members voting Absent: Combs-Flores, Fogg.

- 14.** Annual Agreement with Educational Mental Health Associates

Authorized the Superintendent or designee to enter into an annual agreement with Educational Mental Health Associates to provide educationally related mental health services to eligible students with special needs as described in their Individualized Education Programs.

Motion: Approve, Moved By Board Member Clinton Olivier, Seconded by Board Member Yolanda Moore. Passed. 5-0. Board Members voting Ayes: Awtrey, DeFrank, Moore, Olivier, Stoker Madsen. Board Members voting Absent: Combs-Flores, Fogg.

- 15.** Annual Community Funded Bus Routes

Approved the Community Funded Bus Route requests for the 2024-25 school year, as

submitted.

Motion: Approve, Moved By Board Member Clinton Olivier, Seconded by Board Member Yolanda Moore. Passed. 5-0. Board Members voting Ayes: Awtrey, DeFrank, Moore, Olivier, Stoker Madsen. Board Members voting Absent: Combs-Flores, Fogg.

16. Annual Authorization of Signatures – Check and Payroll Registers

Authorized the Superintendent, Associate Superintendent of Administrative Services, and Assistant Superintendent of Business Services to continue approving and signing check registers and payroll registers, and authorized the Assistant Superintendent of Business Services to receive all District financial mail.

Motion: Approve, Moved By Board Member Clinton Olivier, Seconded by Board Member Yolanda Moore. Passed. 5-0. Board Members voting Ayes: Awtrey, DeFrank, Moore, Olivier, Stoker Madsen. Board Members voting Absent: Combs-Flores, Fogg.

17. Resolutions No. 3992 and 3993 – Annual Workers' Compensation Coverage and General Liability for Volunteer Personnel

Adopted Resolutions No. 3992 and 3993 for workers' compensation and general liability coverage related to volunteer personnel, as submitted.

Motion: Approve, Moved By Board Member Clinton Olivier, Seconded by Board Member Yolanda Moore. Passed. 5-0. Board Members voting Ayes: Awtrey, DeFrank, Moore, Olivier, Stoker Madsen. Board Members voting Absent: Combs-Flores, Fogg.

18. Williams Settlement Complaint Summary Report – Fourth Quarter 2023-24 School Year

Accepted the fourth quarter summary report of zero complaints related to the requirements of the Williams Lawsuit Settlement, as submitted.

Motion: Approve, Moved By Board Member Clinton Olivier, Seconded by Board Member Yolanda Moore. Passed. 5-0. Board Members voting Ayes: Awtrey, DeFrank, Moore, Olivier, Stoker Madsen. Board Members voting Absent: Combs-Flores, Fogg.

M. ACTION

In general (unless otherwise noted), these items were seen for Information at the prior Board meeting and will be voted on at this meeting. Agenda items titled "Annual" are recurring items submitted to the Board for approval yearly.

1. Annual Review of Board Policies No. 5112.5 and No. 6145

Conducted an annual review of Board Policy No. 5112.5 – Open/Closed Campus, Leaving the Campus and Board Policy No. 6145 – Co-Curricular and Extra-Curricular Activities. No vote was taken as no changes were needed.

2. Biennial Review of Board Bylaws and Exhibits No. 9270 – Conflict of Interest Code

Adopted amended Board Bylaws No. 9270, as submitted, and authorized the Superintendent or designee to make modifications to the conflict of interest code as may be required for approval by the County Board of Supervisors.

Motion: Approve, Moved By Board Member Clinton Olivier, Seconded by Board Member Tiffany Stoker Madsen. Passed. 5-0. Board Members voting Ayes: Awtrey, DeFrank, Moore, Olivier, Stoker Madsen. Board Members voting Absent: Combs-Flores, Fogg.

3. Triennial Agreement with ExploreLearning Gizmos

Authorized the Superintendent or designee to enter into an agreement with ExploreLearning Gizmos, a web-based toolkit, effective for a three-year period for school years 2024-25, 2025-26, and 2026-27.

Motion: Approve, Moved By Board Member Tiffany Stoker Madsen, Seconded by Board

Member Yolanda Moore. Passed. 5-0. Board Members voting Ayes: Awtrey, DeFrank, Moore, Olivier, Stoker Madsen. Board Members voting Absent: Combs-Flores, Fogg.

4. Provisional Internship Permits

Approved the Provisional Internship Permits for the recommended teaching candidates, as submitted.

Motion: Approve, Moved By Board Member Clinton Olivier, Seconded by Board Member Tiffany Stoker Madsen. Passed. 5-0. Board Members voting Ayes: Awtrey, DeFrank, Moore, Olivier, Stoker Madsen. Board Members voting Absent: Combs-Flores, Fogg.

5. New Job Description for Purchasing Supervisor

Approved the new Purchasing Supervisor job description, as submitted.

Motion: Approve, Moved By Board Member Clinton Olivier, Seconded by Board Member David DeFrank. Passed. 5-0. Board Members voting Ayes: Awtrey, DeFrank, Moore, Olivier, Stoker Madsen. Board Members voting Absent: Combs-Flores, Fogg.

6. Ratification of the Successor Agreement Contract with CSEA

Accepted the Successor Agreement Contract with CSEA Chapter 250 that was approved by CSEA members in their ratification vote on June 27, 2024.

Motion: Approve, Moved By Board Member David DeFrank, Seconded by Board Member Tiffany Stoker Madsen. Passed. 5-0. Board Members voting Ayes: Awtrey, DeFrank, Moore, Olivier, Stoker Madsen. Board Members voting Absent: Combs-Flores, Fogg.

7. Public Disclosure of Collective Bargaining Agreement Related to Employees

Approved a 5.5% increase to the Classified Operations Unit salary schedule for the 2023-24 fiscal year, retroactive to July 1, 2023.

Motion: Approve, Moved By Board Member Tiffany Stoker Madsen, Seconded by Board Member David DeFrank. Passed. 5-0. Board Members voting Ayes: Awtrey, DeFrank, Moore, Olivier, Stoker Madsen. Board Members voting Absent: Combs-Flores, Fogg.

8. Resolution No. 3997 – Resolution of the Board of Trustees of the Clovis Unified School District Ordering an Election to Authorize the Issuance of School Bonds, Establishing Specifications of the Election Order, and Requesting Consolidation with Other Elections Occurring on November 5, 2024

Adopted Resolution No. 3997 ordering an election to authorize the issuance of \$400 million of general obligation school bonds, establishing specification of the election order and requesting consolidation with the November 5, 2024, Statewide general election to be conducted under Proposition 39 and its related legislation. A roll call vote was held for this item.

Motion: Approve, Moved By Board Member Clinton Olivier, Seconded by Board Member David DeFrank. Passed. 5-0. Board Members voting Ayes: Awtrey, DeFrank, Moore, Olivier, Stoker Madsen. Board Members voting Absent: Combs-Flores, Fogg.

9. Resolution No. 3999 Declaring Intention to Convey an Easement to Pacific Gas and Electric Company and Setting of Public Hearing, Hirayama Elementary School, APN 574-130-01T

Adopted Resolution No. 3999 Declaring Intention to Convey an Easement to Pacific Gas and Electric Company, Hirayama Elementary School, APN 574-130-01T. A roll call vote was held for this item.

Motion: Approve, Moved By Board Member Clinton Olivier, Seconded by Board Member Tiffany Stoker Madsen. Passed. 5-0. Board Members voting Ayes: Awtrey, DeFrank, Moore, Olivier, Stoker Madsen. Board Members voting Absent: Combs-Flores, Fogg.

10. Award of Bid – Supplies

Awarded the following Requests for Proposal (RFP): No. 2991 – Campus Catering – Frozen and Refrigerated Food; RFP No. 2992 – Campus Catering – Processed Commodities; RFP No. 2993 Campus Catering – Milk; RFP No. 2994 – Campus Catering – Paper and Cleaning Supplies; RFP No. 2995 – Campus Catering – Produce; RFP No. 2996 – Campus Catering – Fresh Bread; and RFP No. 2997 – Campus Catering – Dry and Canned Food for future purchases per the attached evaluation score sheets.

Motion: Approve, Moved By Board Member David DeFrank, Seconded by Board Member Tiffany Stoker Madsen. Passed. 5-0. Board Members voting Ayes: Awtrey, DeFrank, Moore, Olivier, Stoker Madsen. Board Members voting Absent: Combs-Flores, Fogg.

N. INFORMATION

Unless otherwise noted, these items are on the agenda to provide time for Board members to review prior to taking action on the items at the next Board meeting. Agenda items titled "Annual" are recurring items submitted to the Board for approval yearly.

1. Extraterritorial Water, Sewer and Related Services and Offsite Infrastructure Agreement Between Clovis Unified School District and the City of Fresno
Approve the Extraterritorial Water, Sewer, and Related Services and Offsite Infrastructure Agreement between Clovis Unified School District and the City of Fresno relating to the Terry P. Bradley Educational Center.
2. Annual Agreements for Students with Special Needs Placed in Non-Public Schools
Authorize Clovis Unified School District to continue agreements with four non-public schools to address the unique educational needs of District students with special needs.
3. Annual Agreement for Student with Special Needs Placed in a Residential Treatment Center
Authorize Clovis Unified School District to continue the agreement with a residential treatment center to address the unique educational needs of a District student with special needs.
4. Resolution No. 3998 – Annual Authorization of Inter-Fund Loans for Cash Flow Purposes
Adopt Resolution No. 3998 authorizing inter-fund loans for cash flow purposes, as submitted.
5. Resolution No. 4000 - Approving Conveyance of Public Utility Easement to Pacific Gas and Electric Company
Adopt Resolution No. 4000 Approving Conveyance of Public Utility Easement to Pacific Gas and Electric Company, APN 574-130-01T (TWO-THIRDS VOTE REQUIRED)
6. Agreement with ParentSquare, Inc.
Approve a three-year agreement with ParentSquare, Inc. for the provision of an integrated two-way communication platform for use at District schools and departments.

O. BOARD SUBCOMMITTEE REPORTS

1. Center for Advanced Research and Technology Board Meeting (Awtrey)

President Awtrey reported that CART is not in session during summer. There were no updates to provide at this time.

P. BOARD MEMBER REPORTS

Q. ADJOURNMENT

President Hugh Awtrey adjourned the Governing Board meeting at 7:21 p.m.

RESPECTFULLY SUBMITTED:

Clerk

Secretary

CONTACT PERSON: Michael Johnston

FOR INFORMATION:

FOR ACTION: August 7, 2024

RECOMMENDATION:

Ratify Purchase Orders, District Contracts, and Warrants numbered 678078 through 678853.

DISCUSSION:

District Administration recommends ratification of the Purchase Orders and District Contracts for the period of July 1, 2024-July 21, 2024, as well as the Warrant register for July 2, 2024-July 18, 2024. This information is available for review in the Purchasing and Accounting departments. Questions may be directed to the Business Services Department at 559-327-9127.

FISCAL IMPACT/FUNDING SOURCE:

ATTACHMENTS:

Description

Upload Date

Type

REVISIONS:

CONTACT PERSON: Michael Johnston

FOR INFORMATION:

FOR ACTION: August 7, 2024

RECOMMENDATION:

Approve the Change Orders, as submitted.

DISCUSSION:

Change Order Number	Contract/ Bid Number	Project Type	Site(s)	DSA Number
CES-0207	Bid 2922	New Construction - 2023	Hirayama Elementary School – Phase 1 and 2	02-120543
CES-0709	Bid 2922	New Construction - 2023	Hirayama Elementary School – Phase 1 and 2	02-120543
CES-0906	Bid 2922	New Construction - 2023	Hirayama Elementary School – Phase 1 and 2	02-120543
CES-1205	Bid 2922	New Construction - 2023	Hirayama Elementary School – Phase 1 and 2	02-120543
CES-1403	Bid 2922	New Construction - 2023	Hirayama Elementary School – Phase 1 and 2	02-120543
CES-1507	Bid 2922	New Construction - 2023	Hirayama Elementary School – Phase 1 and 2	02-120543
CSI-02a01	Bid 2983	Security Improvements - 2024	Campus Security Improvements – Phase 2	NA
DOE-0206	Bid 2965	New Construction – 2024	District Campus - Phase 1	02-120813
DOE-0603	Bid 2965	New Construction – 2024	District Campus - Phase 1	02-120813
DOE-1103	Bid 2965	New Construction – 2024	District Campus - Phase 1	02-120813
DOE-1203	Bid 2965	New Construction – 2024	District Campus - Phase 1	02-120813

FISCAL IMPACT/FUNDING SOURCE:

As noted in the attachment.

ATTACHMENTS:

Description	Upload Date	Type
Change Orders	7/15/2024	Backup Material

REVISIONS:

Contract Change Order No. 07

Project Hirayama Elem. Sch. Phase 1 & **Date** 8/7/2024
 2 (2023) 35060 (Fowler
 McKinley)
Bid No./Contract Bid No. 2922 /CES-02
 (3230564) Bid 2922 (Phase 1)

Description CES-02-CO7

From Clovis Unified School District **To** JT2, Inc. dba Todd Companies
 1470 Herndon Avenue P.O. Box 6820
 Clovis, CA 93611 Visalia, California 93290

Item No.	Item Description	Item Amount	Reason for Change
01	Interim housing underground utilities.	\$11,855.00	Unforeseen Condition

Description: Interim housing underground utilities.
 Requested By: Unforeseen Condition. \$11,855.00 to be added to the contract
 Reason for Change: Unforeseen Condition. Due to delays caused by The Division of the State Architect during plan review, temporary modular buildings will be utilized for the beginning of the school year. Temporary plumbing will be installed for the restroom portables.

Total for this Current CCO \$11,855.00

CONTRACT SUMMARY:

Original Contract	\$1,133,475.00
Pending CCOs (Including Current CCO)	\$25,640.00
Previous Approved CCOs	\$69,324.00
Total Contract	\$1,228,439.00

The revised contract amount is an increase of 8.38% from the original amount.

Contract Change Order No. 09

Project Hirayama Elem. Sch. Phase 1 & 2 (2023) 35060 (Fowler McKinley) **Date** 8/7/2024
Bid No./Contract Bid No. 2922 /CES-07 (3240064) Bid 2923 (Phase 2)

Description CES-07-C09

From Clovis Unified School District
 1470 Herndon Avenue
 Clovis, CA 93611 **To** DAC Service Inc., dba Four C's Construction
 1560 H Street
 Fresno, California 93721

Item No.	Item Description	Item Amount	Reason for Change
01	Revisions to Densdeck.	\$2,136.00	Unforeseen Condition

Description: Revisions to Densdeck.
 Requested By: Unforeseen Condition. \$2,136.00 to be added to the contract.
 Reason for Change: Unforeseen Condition. 5/8" Densdeck will be utilized at the canopy decks for Buildings B, C, and D to span flutes in lieu of 1/4" Densdeck. The 1/4" Densdeck will not span the required 6" on center top flutes of the steel deck however, 5/8" Densdeck spans up to 8".

Item No.	Item Description	Item Amount	Reason for Change
02	Overtime for May.	\$2,956.00	Unforeseen Condition

Description: Overtime for May.
 Requested By: Unforeseen Condition. \$2,956.00 to be added to the contract.
 Reason for Change: Unforeseen Condition. Due to delays caused by The Division of the State Architect, overtime for roofing at Building A was required to maintain the project completion date.

Total for this Current CCO \$5,092.00

CONTRACT SUMMARY:

Original Contract	\$3,656,900.00
Pending CCOs (Including Current CCO)	\$20,418.00
Previous Approved CCOs	\$73,192.00
Total Contract	\$3,750,510.00

The revised contract amount is an increase of 2.56% from the original amount.

Contract Change Order No. 06

Project Hirayama Elem. Sch. Phase 1 & 2 (2023) 35060 (Fowler McKinley) **Date** 8/7/2024
Bid No./Contract Bid No. 2922 /CES-09 (3230819) Bid 2923 (Phase 2)

Description CES-09-CO6

From Clovis Unified School District
 1470 Herndon Avenue
 Clovis, CA 93611 **To** Karsyn Construction, Inc.
 4697 W. Jacquelyn Avenue
 Fresno, California 93722

Item No.	Item Description	Item Amount	Reason for Change
01	Building E overtime for plaster.	\$832.00	Unforeseen Condition

Description: Building E overtime for plaster.
 Requested By: Unforeseen Condition. \$832.00 to be added to the contract.
 Reason for Change: Unforeseen Condition. Due to delays caused by the Division of the State Architect, overtime was required for plaster at Building E to maintain the project completion date.

Total for this Current CCO \$832.00

CONTRACT SUMMARY:

Original Contract	\$6,350,000.00
Pending CCOs (Including Current CCO)	\$21,807.00
Previous Approved CCOs	\$104,093.00
Total Contract	\$6,475,900.00

The revised contract amount is an increase of 1.98% from the original amount.

Contract Change Order No. 05

Project Hirayama Elem. Sch. Phase 1 & **Date** 8/7/2024
 2 (2023) 35060 (Fowler
 McKinley)
Bid No./Contract Bid No. 2922 /CES-12
 (3230822) Bid 2923 (Phase 2)

Description CES-12-CO5

From Clovis Unified School District **To** Better Enterprises, Inc.
 1470 Herndon Avenue 1148 N Cypress Ave
 Clovis, CA 93611 Fresno, California 93727

Item No.	Item Description	Item Amount	Reason for Change
01	Tile base at Janitor Rooms.	\$11,135.00	Agency Requirement

Description: Tile base at Janitor Rooms.
 Requested By: Agency Requirement. \$11,135.00 to be added to the contract.
 Reason for Change: Agency Requirement. The Health Department required 6" ceramic tile to be installed at the base of all Janitor Rooms in lieu of 6" rubber base.

Item No.	Item Description	Item Amount	Reason for Change
02	Underlayment for flooring installed at Building P.	\$16,187.00	Agency Requirement

Description: Underlayment for flooring installed at Building P.
 Requested By: Agency Requirement. \$16,187.00 to be added to the contract.
 Reason for Change: Agency Requirement. The manufacturer for the flooring at Building P required an underlayment to be installed for the flooring due to expansion joints.

Item No.	Item Description	Item Amount	Reason for Change
03	Signage changes.	\$2,869.00	Agency Requirement

Description: Signage changes.
 Requested By: Agency Requirement. \$2,869.00 to be added to the contract.
 Reason for Change: Agency Requirement. The Division of the State Architect requested assistive listening signs be added at Buildings B, C, D, and E to meet ADA requirements.

Total for this Current CCO \$30,191.00

CONTRACT SUMMARY:

Original Contract	\$5,473,071.00
Pending CCOs (Including Current CCO)	\$(7,141.00)
Previous Approved CCOs	\$(33,209.81)
Total Contract	\$5,432,720.19

The revised contract amount is a decrease of -0.74% from the original amount.

Contract Change Order No. 03

Project Hirayama Elem. Sch. Phase 1 & **Date** 8/7/2024
 2 (2023) 35060 (Fowler
 McKinley)
Bid No./Contract Bid No. 2922 /CES-14
 (3240059) Bid 2923 (Phase 2)

Description CES-14-CO3

From Clovis Unified School District **To** JT2, Inc. dba Todd Companies
 1470 Herndon Avenue P.O. Box 6820
 Clovis, CA 93611 Visalia, California 93290

Item No.	Item Description	Item Amount	Reason for Change
01	Added washer and dryer plumbing.	\$9,121.00	A&E Omission

Description: Added washer and dryer plumbing.
 Requested By: A&E Omission. \$9,121.00 to be added to the contract.
 Reason for Change: A&E Omission. A washer and dryer were added at Building E. Additional plumbing and venting was required to accommodate the new appliances.

Total for this Current CCO \$9,121.00

CONTRACT SUMMARY:

Original Contract	\$3,568,730.00
Pending CCOs (Including Current CCO)	\$11,201.00
Previous Approved CCOs	\$29,050.00
Total Contract	\$3,608,981.00

The revised contract amount is an increase of 1.13% from the original amount.

Contract Change Order No. 07

Project Hirayama Elem. Sch. Phase 1 & 2 (2023) 35060 (Fowler McKinley) **Date** 8/7/2024
Bid No./Contract Bid No. 2922 /CES-15 (3230818) Bid 2932 (Phase 2)

Description CES-15-CO7

From Clovis Unified School District
 1470 Herndon Avenue
 Clovis, CA 93611 **To** Wild Electric
 4626 E. Olive Ave.
 Fresno, California 93702

Item No.	Item Description	Item Amount	Reason for Change
01	Overtime for May.	\$4,530.00	Unforeseen Condition

Description: Overtime for May.
 Requested By: Unforeseen Condition. \$4,530.00 to be added to the contract.
 Reason for Change: Unforeseen Condition. Due to delays caused by The Division of the State Architect, overtime for rough-in at Building E was required to maintain the project completion date.

Item No.	Item Description	Item Amount	Reason for Change
02	Overtime for first part of June.	\$18,515.00	Unforeseen Condition

Description: Overtime for first part of June.
 Requested By: Unforeseen Condition. \$18,515.00 to be added to the contract.
 Reason for Change: Unforeseen Condition. Due to delays caused by The Division of the State Architect, overtime for electrical rough-in at Buildings K1, K2, and E was required to maintain the project completion date.

Total for this Current CCO **\$23,045.00**

CONTRACT SUMMARY:

Original Contract	\$4,632,000.00
Pending CCOs (Including Current CCO)	\$425,619.00
Previous Approved CCOs	\$42,648.65
Total Contract	\$5,100,267.65

The revised contract amount is an increase of 10.11% from the original amount.

Contract Change Order No. 01

Project Campus Security Improvements **Date** 8/7/2024
Phase 2 (2024) 20008
Bid No./Contract Bid No. 2983 /CSI-02a
(3250001)

Description CSI-02a-C01

From Clovis Unified School District
1470 Herndon Avenue
Clovis, CA 93611 **To** EKC Enterprises Inc.
4658 E. Weathermaker
Fresno, California 93703

Item No.	Item Description	Item Amount	Reason for Change
01	Equipment added stock.	\$22,151.59	District Change

Description: Equipment added stock.
Requested By: District Change. \$22,151.59 to be added to the contract.
Reason for Change: District Change. The District requested additional door enclosure equipment as added stock, in case existing equipment fails and needs to be replaced.

Item No.	Item Description	Item Amount	Reason for Change
02	Districtwide access keycards.	\$60,115.97	District Change

Description: Districtwide access keycards.
Requested By: District Change. \$60,115.97 to be added to the contract.
Reason for Change: District Change. Contractor shall provide all remaining access control cards for campuses associated with remaining packages 3-7. Purchasing the cards early will avoid any potential lead times associated with the cards on future phases.

Total for this Current CCO \$82,267.56

CONTRACT SUMMARY:

Original Contract	\$1,478,000.00
Pending CCOs (Including Current CCO)	\$82,267.56
Previous Approved CCOs	\$0.00
Total Contract	\$1,560,267.56

The revised contract amount is an increase of 5.57% from the original amount.

Contract Change Order No. 06

Project District Campus Ph. 1 (2023) **Date** 8/7/2024
 37046
Bid No./Contract Bid No. 2965 /DOE-02
 (3240386)

Description PW: Fresno Irrigation District (FID) bond.

From Clovis Unified School District **To** American Inc.
 1470 Herndon Avenue 1345 North American St
 Clovis, CA 93611 Visalia, California 93291-9334

Item No.	Item Description	Item Amount	Reason for Change
01	PW: FID bond.	\$1,439.00	Agency Requirement

Description: PW: FID bond.
 Requested By: Agency Requirement. \$1,439.00 to be added to the contract.
 Reason for Change: Agency Requirement. Additional bond required by Fresno Irrigation District (FID) for replacement of existing 24" FID line.

Total for this Current CCO \$1,439.00

CONTRACT SUMMARY:

Original Contract	\$1,234,927.00
Pending CCOs (Including Current CCO)	\$1,439.00
Previous Approved CCOs	\$87,990.94
Total Contract	\$1,324,356.94

The revised contract amount is an increase of 7.24% from the original amount.

Contract Change Order No. 03

Project District Campus Ph. 1 (2023) **Date** 8/7/2024
 37046
Bid No./Contract Bid No. 2965 /DOE-06
 (3240388)

Description OL: Revised Casework

From Clovis Unified School District **To** TMR Executive Interiors, Inc.
 1470 Herndon Avenue 1287 W. Nielsen Avenue
 Clovis, CA 93611 Fresno, California 93706-1395

Item No.	Item Description	Item Amount	Reason for Change
01	OL: Revised casework.	\$30,639.06	District Change

Description: OL: Revised casework.
 Requested By: District Change. \$30,639.06 to be added to the contract.
 Reason for Change: District Change. District requested revision to add revised storage space to the reception and office spaces.

Item No.	Item Description	Item Amount	Reason for Change
02	SPED: Revised Casework.	\$9,513.14	District Change

Description: SPED: Revised Casework.
 Requested By: District Change. \$9,513.14 to be added to the contract.
 Reason for Change: District Change. District requested revision to add revised storage space to the reception and office spaces.

Total for this Current CCO \$40,152.20

CONTRACT SUMMARY:

Original Contract	\$999,998.34
Pending CCOs (Including Current CCO)	\$29,967.97
Previous Approved CCOs	\$0.00
Total Contract	\$1,029,966.31

The revised contract amount is an increase of 3% from the original amount.

Contract Change Order No. 03

Project District Campus Ph. 1 (2023) **Date** 8/7/2024
 37046
Bid No./Contract Bid No. 2965 /DOE-11 (3240392)

Description PW: Floor protection OT.

From Clovis Unified School District
 1470 Herndon Avenue
 Clovis, CA 93611 **To** Wm. B. Saleh Co.
 1364 N. Jackson
 Fresno, California 93703

Item No.	Item Description	Item Amount	Reason for Change
01	PW: Floor protection.	\$600.00	District Change

Description: PW: Floor protection.
 Requested By: District Change. \$600.00 to be added to the contract.
 Reason for Change: District Change. Skudo floor protection installation completed on Saturday to allow for 24 hour cure time.

Item No.	Item Description	Item Amount	Reason for Change
02	OL: Concrete seal the I.T. (Information Technology room).	\$591.00	District Change

Description: OL: Concrete seal the I.T. (Information Technology room).
 Requested By: District Change. \$591.00 to be added to the contract.
 Reason for Change: District Change. IT room flooring revised from VCT (vinyl ceramic tile) to sealed concrete.

Item No.	Item Description	Item Amount	Reason for Change
03	SPED: Concrete seal I.T. (information technology) room.	\$888.00	District Change

Description: SPED: Concrete seal I.T. (Information Technology) room.
 Requested By: District Change. \$888.00 to be added to the contract.
 Reason for Change: District Change. I.T. room flooring revised from VCT (vinyl ceramic tile) to sealed concrete.

Total for this Current CCO \$2,079.00

CONTRACT SUMMARY:

Original Contract	\$378,400.00
Pending CCOs (Including Current CCO)	\$11,462.00
Previous Approved CCOs	\$0.00
Total Contract	\$389,862.00

The revised contract is an increase of 3.03% from the original amount.

Contract Change Order No. 03

Project District Campus Ph. 1 (2023) **Date** 8/7/2024
 37046
Bid No./Contract Bid No. 2965 /DOE-12
 (3240393)

Description OL: Informational Technology (I.T.) room vinyl composition tile (VCT) credit.

From Clovis Unified School District **To** Better Enterprises, Inc.
 1470 Herndon Avenue 1148 N Cypress Ave
 Clovis, CA 93611 Fresno, California 93727

Item No.	Item Description	Item Amount	Reason for Change
01	OL: Informational Technology (I.T.) room vinyl composition tile (VCT) credit.	\$(683.24)	District Change

Description: OL: Informational Technology (I.T.) room vinyl composition tile (VCT) credit.
 Requested By: District Change. \$(683.24) to be credited to the contract.
 Reason for Change: District Change. Topical concrete vapor control barrier was requested to be eliminated at areas receiving polished concrete. Revising VCT to sealed concrete allowed for a barrier to be placed in controlled location within the building.

Item No.	Item Description	Item Amount	Reason for Change
02	SPED: Informational Technology (I.T.) room vinyl composition tile (VCT) credit.	\$(1,024.85)	District Change

Description: SPED: Informational Technology (I.T.) room vinyl composition tile (VCT) credit.
 Requested By: District Change. \$(1,024.85) to be credited to the contract.
 Reason for Change: District Change. Topical concrete vapor control barrier was requested to be eliminated at areas receiving polished concrete. Revising VCT to sealed concrete allowed for a barrier to be placed in controlled location within the building.

Total for this Current CCO \$(1,708.09)

CONTRACT SUMMARY:

Original Contract	\$3,131,408.68
Pending CCOs (Including Current CCO)	\$20,681.45
Previous Approved CCOs	\$0.00
Total Contract	\$3,152,090.13

The revised contract amount is an increase of 0.66% from the original contract amount.

Title: Annual Agreements for Students with Special Needs Placed in Non-Public Schools

CONTACT PERSON: Norm Anderson

FOR INFORMATION: July 17, 2024

FOR ACTION: August 7, 2024

RECOMMENDATION:

Authorize Clovis Unified School District to continue agreements with four non-public schools to address the unique educational needs of District students with special needs.

DISCUSSION:

Based on the Individualized Education Program recommendations, it has been determined that special needs students previously placed in a non-public school continue to require services in a non-public school in order to address the students' unique educational needs for the 2024-25 school year.

Non-Public School	Location	Not to Exceed Amount
Apique/AMVA Corporation	Fresno	\$101,000
Creative Alternatives	Fresno	\$216,000
Central Valley Training Center	Fresno	\$ 60,000
Learn It Systems, LLC	Fresno	\$135,000

Clovis Unified will review the cases every six months to determine the appropriateness of the placement and whether less restrictive placements can meet the students' unique educational needs.

FISCAL IMPACT/FUNDING SOURCE:

Costs are included in the 2024-25 Special Education Budget.

REVISIONS:

Title: Annual Agreement for Student with Special Needs Placed in a Residential Treatment Center

CONTACT PERSON: Norm Anderson

FOR INFORMATION: July 17, 2024

FOR ACTION: August 7, 2024

RECOMMENDATION:

Authorize Clovis Unified School District to continue the agreement with a residential treatment center to address the unique educational needs of a District student with special needs.

DISCUSSION:

Based on the Individualized Education Program recommendations, it has been determined that a special needs student previously placed in a residential treatment center, continues to require those services in order to address the student's unique educational needs for the 2024-25 school year.

Residential Treatment Center	Location	Not to Exceed Amount
Copper Hills Youth Center	West Jordan, UT	\$76,000

Clovis Unified will review the case every six months to determine the appropriateness of the placement and whether a less restrictive placement can meet the student's unique educational needs.

FISCAL IMPACT/FUNDING SOURCE:

Cost is included in the 2024-25 Special Education Budget.

REVISIONS:



Title: Agreement with ParentSquare, Inc.

CONTACT PERSON: Kelly Avants

FOR INFORMATION: July 17, 2024

FOR ACTION: August 7, 2024

RECOMMENDATION:

Approve a three-year agreement with ParentSquare, Inc. for the provision of an integrated two-way communication platform for use at District schools and departments, as submitted.

DISCUSSION:

ParentSquare is a communication platform that allows educators to consolidate multiple school-to-home communication methods into one easy-to-use portal for parents. Combining text, voice, email, direct message and internet options, ParentSquare would allow the District to simplify communication with parents and create consistency across school sites and programs. This outcome would address feedback received over time from parents seeking easier ways to stay engaged with their child's school while also making it easier for staff to communicate. The platform also features translation capabilities to increase engagement with second language families as well as secure document delivery, a content management system, social media integration, attendance, reporting and online payment features.

For the above reasons, the District piloted (at no cost) this platform during the 2024 Summer Session. Based on the positive review by users along with additional due diligence research by the Communications and Technology departments, the District has determined to move forward with rolling out ParentSquare with the start of the 2024-25 school year. The fall semester would be used to navigate a shift from existing, disparate platforms in use across the District to ParentSquare.

The chart below summarizes one-time, on-going and potential future expenses to implement the platform at all of our schools and programs. If approved, expenses already in the budget that currently pay for the District's auto notification/email/text/website/app systems, along with purchases of a variety of communication platforms in use by individual schools and/or programs, would be replaced as contracts expire. This would allow costs associated with this agreement to be offset by savings in other platforms no longer used in the District.

FISCAL IMPACT/FUNDING SOURCE:

	2024-25	2025-26	2026-27
Onboarding (one-time)	\$ 46,000		
Ongoing Expense	\$ 196,800	\$ 293,400	\$ 293,400
Total Cost of Software	\$ 242,800	\$ 293,400	\$ 293,400
Less District level software savings	\$ (42,153)	\$ (84,305)	\$ (84,305)

Total Fiscal Impact	\$ 200,647	\$ 209,095	\$ 209,095

REVISIONS:

CONTACT PERSON: Marc Hammack

FOR INFORMATION:

FOR ACTION: August 7, 2024

RECOMMENDATION:

Approve the Clovis Adult Education course offerings for the 2024-25 school year, as submitted.

DISCUSSION:

Attached is a list of courses sent to and approved by the California Department of Education for the 2024-25 Clovis Adult Education school year. Having received this approval on July 19, 2024, this item is going straight for Action to obtain approval from the Governing Board before classes start in August. Copies of the course outlines are available for review in the office of the Principal of Clovis Adult Education.

FISCAL IMPACT/FUNDING SOURCE:

No fiscal impact.

ATTACHMENTS:

Description	Upload Date	Type
Course Approval Letter	7/24/2024	Backup Material

REVISIONS:

California Department of Education

Date: July 19, 2024

To: Marci Panoo
Clovis Adult Education

CDS:10 - 62117

From: Adult Education Office
Neil Kelly
nkelly@cde.ca.gov
916-322-2175
Adult Education Office, California Department of Education
Education Programs Consultant

Subject: Course Approval for 2024-2425

Your request for approval of the following 42 courses have been received, recorded, and approved for the 2024 - 2025 school year.

Number	Name	Course Outline Year	Study Date
9980	Advanced ESL	2023	
7942	Advanced Healthcare Operational Support (Capstone)	2024	2024
7922	Advanced Patient Care (Capstone)	2024	2024
2403	Algebra 1	2023	
2816	Art Appreciation	2023	
2803	Art History	2023	
2102	Basic English	2023	
2402	Basic Mathematics	2023	
9982	Beginning ESL	2023	
2603	Biology	2023	
9978	Career Exploration	2023	
9994	Civic Engagement Elective	2023	
2618	Earth Science	2023	
2701	Economics	2023	
2131	English 10	2023	
2132	English 11	2023	
2133	English 12	2023	
2130	English 9	2023	
2198	English Elective	2023	
9986	ESL MultiLevel	2023	
2710	Ethnic Studies	2023	
4361	Food and Nutrition	2023	
9983	General ESL	2023	
2400	General Mathematics	2023	
2611	General Science	2023	
9972	Government	2023	

9995	Government and History (Citizenship Preparation)	2023	
2535	Health	2023	
4391	Individual and Family Health	2023	
9981	Intermediate ESL	2023	
7961	Intermediate Mental and Behavioral Health (Concentrator)	2024	2024
7921	Intermediate Patient Care (Concentrator)	2024	2024
7930	Introduction to Healthcare Administrative Services	2024	2024
7920	Introduction to Patient Care	2024	2024
2621	Life Science	2023	
2702	Physical Geography	2023	
2610	Physical Science	2023	
2714	Psychology	2023	
2206	Spanish	2023	
9969	Test Preparation	2023	
2711	World History: Survey	2023	
2724	World Regional Geography	2023	

You are authorized to expend California Adult Education Program funds for the above courses. It is recommended that you use these Course Titles with additional supporting classes listed when communicating program offerings to the public.

Course Outlines for all apportionment classes shall be on file and available for review at the adult school or the district office (5 CCR 10508).

To meet optimum educational standards, these course outlines should contain:

- Goals and purposes
- Performance objectives or competencies
- Instructional strategies
- Units of study, with approximate hours allotted for each unit
- Evaluation procedures
- Clear course completion requirements of established goals and objectives

[ED 51056; 52504; 52506; 5CCR 10508 (b)
Adult Education Handbook for California (2023)

Career Technical Education: Before establishing a career technical education training program, each member of a local adult education consortium, or the consortium as a whole, shall conduct a job market study of the labor market area in which it proposes to establish the career technical education training program or rely upon the most recent job market study of the labor market area conducted by the local workforce development board. The study shall use local labor market information and consider a supply analysis of existing career technical education training programs for adults maintained by high schools, community colleges, and other postsecondary educational institutions in the geographic area to ensure that the anticipated employment demand for adults enrolled in the proposed training program justifies the establishment of the proposed courses of instruction (EC 84906(a)(3)(A).

After completing the job market study and before establishing the career technical education training program, the governing body of a member of a local adult education consortium, or the consortium as a whole, as applicable, shall determine if the job market study justifies the proposed career technical education program (EC 84906(a)(3)(B).

Refer to the Job Market Study in 84906(a) for more information. Education Codes: 1900; 41976; 52506; 52515; 52518; 52570.

CONTACT PERSON: Michael Johnston

FOR INFORMATION: July 17, 2024

FOR ACTION: August 7, 2024

RECOMMENDATION:

Adopt Resolution No. 3998 authorizing inter-fund loans for cash flow purposes, as submitted.

DISCUSSION:

California Education Code section 42603 authorizes school districts to make inter-fund loans between funds. It is in the best interest of the District to allow such loans in order to facilitate the investing of money and to avoid having to borrow money from outside financial institutions when one of the funds may have a cash shortage. This inter-fund loan process is utilized only as authorized by the California Education Code, which requires that the loan be repaid in the same year, or subsequent year, if borrowing takes place within 120 days of the fiscal year-end. The Education Code also does not allow more than 75% of the money held in any fund during the current fiscal year to be transferred. District Administration recommends the Board approve a resolution authorizing these inter-fund loans during the fiscal year of 2024-25, as needed.

FISCAL IMPACT/FUNDING SOURCE:

No fiscal impact.

ATTACHMENTS:

Description	Upload Date	Type
Resolution No. 3998	7/31/2024	Backup Material

REVISIONS:

**RESOLUTION NO. 3998
BEFORE THE GOVERNING BOARD
OF THE CLOVIS UNIFIED SCHOOL DISTRICT
FRESNO COUNTY, CALIFORNIA**

**RESOLUTION FOR ANNUAL AUTHORIZATION
OF INTER-FUND LOANS FOR CASH FLOW
PURPOSES**

WHEREAS, the Governing Board of Clovis Unified School District may direct that moneys held in any fund or account may be temporarily transferred to another fund or account of the district for payments of obligations as authorized by Education Code Section 42603; and

WHEREAS, the transfer shall be accounted for as temporary borrowing between funds or accounts and shall not be available for appropriation or be considered income to the borrowing fund or account; and

WHEREAS, amounts transferred shall be repaid either in the same fiscal year, or in the following fiscal year if the transfer takes place within the final 120 calendar days of a fiscal year.

NOW THEREFORE, BE IT RESOLVED that the Governing Board of the Clovis Unified School District, in accordance with the provisions of Education Code Section 42603 adopts the following authorization for the 2024-25 fiscal year to temporarily transfer moneys between District funds provided that all transfers are approved by the Superintendent or designee.

THE FOREGOING RESOLUTION was adopted by the Governing Board of the Clovis Unified School District of Fresno County, State of California, at a meeting of said Board held on the 7th day of August, 2024, by the following vote:

AYES:

NOES:

ABSENT:

ABSTAIN:

Hugh Awtrey, President
Governing Board
Clovis Unified School District
Fresno County, California

I, Clinton Olivier, Clerk of the Governing Board of the Clovis Unified School District, County of Fresno, State of California, do hereby certify that the foregoing is a true copy of the resolution adopted by said Board at a regular meeting thereof, at the time and by the vote therein stated, which original resolution is on file in the office of said Board.

Clinton Olivier, Clerk
Governing Board
Clovis Unified School District
Fresno County, California

Title: Resolution No. 4000 - Approving Conveyance of Public Utility Easement to Pacific Gas and Electric Company, APN 574-130-01T

CONTACT PERSON: Michael Johnston

FOR INFORMATION: July 17, 2024

FOR ACTION: August 7, 2024

RECOMMENDATION:

Adopt Resolution No. 4000 approving the conveyance of a public utility easement to Pacific Gas and Electric Company, regarding APN 574-130-01T (TWO-THIRDS VOTE REQUIRED).

DISCUSSION:

Clovis Unified School District (District) owns the real property located between McKinley and Clinton avenues, and Fowler and Armstrong avenues in the City of Fresno, County of Fresno, State of California and designated as a portion of APN 574-130-01T (Property).

The District has undertaken a public works project to design and construct a new elementary school (Project) on the Property.

To connect gas, electricity, and other services to the Property, work is needed by Pacific Gas and Electric Company (PGE), a public utility, to excavate, construct, install and maintain certain facilities and equipment. PGE desires to acquire an easement over a portion of the Property for the purpose of excavating, constructing, reconstructing, replacing, removing, maintaining, inspecting, and using such facilities and equipment. The Easement Deed that is part of the proposed resolution is attached hereto.

The conveyance of the easement to PGE is authorized by the California Education Code. Pursuant to Education Code section 17556, a school district governing board may dedicate or convey to any public corporation or private corporation engaged in the public utility business an easement to lay, construct, reconstruct, maintain, and operate water, sewer, gas, or storm drain pipes or ditches, electric or telephone lines, and access roads used in connection therewith, over and upon any land belonging to the school district, upon such terms and conditions as agreed to by the parties. Education Code section 17559 requires the governing board, by not less than a two-thirds vote of all of its board members, to adopt a resolution authorizing and directing the execution of a deed of dedication or conveyance of the property and deliver it.

At its regular Board meeting on July 17, 2024, the Board voted to adopt Resolution No. 3999, declaring its intention to convey a public utility easement to PGE and setting a Public Hearing to be held this August 7, 2024, Board meeting. Notice of the public hearing was posted and published in accordance with Education Code section 17558. No protest has been filed under Education Code section 17560.

By adopting the proposed resolution attached hereto, the Board would approve the conveyance of the utility easement, as described in Exhibit A, to PGE and authorize and direct the Superintendent or designee to execute and deliver to PGE an easement deed or similar

instrument(s).

FISCAL IMPACT/FUNDING SOURCE:

Not Applicable

ATTACHMENTS:

Description	Upload Date	Type
Resolution No. 4000	8/5/2024	Backup Material

REVISIONS:

**RESOLUTION NO. 4000
BEFORE THE GOVERNING BOARD
OF THE CLOVIS UNIFIED SCHOOL DISTRICT
FRESNO COUNTY, CALIFORNIA**

**APPROVAL OF CONVEYANCE OF A PUBLIC UTILITY EASEMENT TO
PACIFIC GAS AND ELECTRIC COMPANY
APN 574-130-01T**

WHEREAS, Clovis Unified School District (District) owns the real property located between McKinley Avenue and Clinton Avenue, and Fowler Avenue and Armstrong Avenue in the City of Fresno, County of Fresno, State of California and designated as a portion of APN 574-130-01T (Property); and

WHEREAS, The District has undertaken a public works project to design and construct a new elementary school (Project) on the Property. The Project is anticipated to be completed by Fall 2024; and

WHEREAS, to connect gas, electricity, and other services to the Property, work is needed by Pacific Gas and Electric Company (PGE), a public utility, to excavate, construct, install and maintain certain facilities and equipment. PGE desires to acquire an easement over a portion of the Property for the purpose of excavating, constructing, reconstructing, replacing, removing, maintaining, inspecting, and using such facilities and equipment (Utility Improvement Purposes). The Deed of Easement and attached map (Easement Area) is set forth in the attached Exhibit A; and

WHEREAS, the Easement Area is not now and will not at the time of the proposed delivery of possession and title to PGE be needed exclusively for classroom or other school purposes by the District; and

WHEREAS, the Utility Improvement Purposes to be carried out by PGE will benefit the District; and

WHEREAS, it is in the best interest of the District to transfer ownership of said Easement Area to PGE in that PGE will carry out the Utility Improvement Purposes.

WHEREAS, pursuant to Education Code section 17556, a school district governing board may dedicate or convey to any public corporation or private corporation engaged in the public

utility business an easement to lay, construct, reconstruct, maintain, and operate water, sewer, gas, or storm drain pipes or ditches, electric or telephone lines, and access roads used in connection therewith, over and upon any land belonging to the school district, upon such terms and conditions as agreed to by the parties; and

WHEREAS, Education Code section 17557 requires the governing board, by not less than a two-thirds vote of all of its board members, to adopt a resolution declaring its intention to dedicate or convey the easement and set a public hearing not less than 10 days thereafter on the question of making the conveyance. At its regular Board meeting on July 17, 2024, the Board adopted Resolution No. 3999, declaring its intention to convey a public utility easement to PGE and setting a public hearing to be held on August 7, 2024. Notice of the public hearing was posted and published in accordance with Education Code section 17558. On August 7, 2024, the Board held a public hearing regarding the conveyance of the public utility easement to PGE; and

WHEREAS, Education Code section 17559 requires the governing board, by not less than a two-thirds vote of all of its board members, to adopt a resolution authorizing and directing the execution of a deed of dedication or conveyance of the property and deliver it. By this resolution, the Board intends to authorize and direct the Superintendent or designee to execute the deed of conveyance of the Property and deliver it to PGE; and

WHEREAS, no protest has been filed under Education Code section 17560.

THEREFORE, BE IT RESOLVED that the District's Governing Board hereby:

1. Declares and adopts the foregoing recitals as true and correct.
2. Pursuant to Education Code section 17556 et seq., conveys the Easement Area to PGE for the Utility Improvement Purposes, which Easement Area is set forth in Exhibit A.
3. Authorizes and directs the Superintendent or designee to execute and deliver to PGE the Easement Deed attached as Exhibit A or similar instrument(s), with such modifications thereto as the Superintendent or designee determines appropriate and agreed upon with PGE, to convey the Easement Area to PGE for the Utility Improvement Purposes.
4. This Resolution shall take effect immediately upon its adoption.

THE FOREGOING RESOLUTION was adopted by the Governing Board of the Clovis Unified School District of Fresno County, State of California, at a regular meeting of said Board held on this 7th day of August 2024, by the following vote:

AYES:

NOES:

ABSENT:

ABSTAIN:

Hugh Awtrey, President
Governing Board
Clovis Unified School District
Fresno County, California

I, Clinton Olivier, the Clerk of the Governing Board of the Clovis Unified School District, County of Fresno, State of California, do hereby certify that the foregoing is a true copy of the Resolution adopted by said Board at a regular meeting there, at the time and by the vote therein stated, which original resolution is on file in the office of said Board.

Clinton Olivier, Clerk
Governing Board
Clovis Unified School District
Fresno County, California

Doc# 83937, 07/2024

EXHIBIT A

DEED OF EASEMENT

RECORDING REQUESTED BY AND RETURN TO:

***PACIFIC GAS AND ELECTRIC COMPANY
300 Lakeside Drive, Suite 210
Oakland, CA 94612
Attn: Land Rights Library***

Location: City of Fresno, Fresno Co.

Recording Fee \$ _____

Document Transfer Tax \$ 0.00

This is a conveyance where the consideration and Value is less than \$100.00 (R&T 11911).

Computed on Full Value of Property Conveyed, or

Computed on Full Value Less Liens

& Encumbrances Remaining at Time of Sale

Exempt from the fee per GC 27388.1 (a) (2); This document is subject to Documentary Transfer Tax

(SPACE ABOVE FOR RECORDER'S USE ONLY)

Signature of declarant or agent determining tax

LD #2213-21-

EASEMENT DEED

CLOVIS UNIFIED SCHOOL DISTRICT, a California unified school district,

hereinafter called Grantor, hereby grants to PACIFIC GAS AND ELECTRIC COMPANY, a California corporation, hereinafter called Grantee, the right from time to time to excavate for, construct, reconstruct, replace (of initial or any other size), remove, maintain, inspect, and use facilities and associated equipment for public utility purposes, including, but not limited to electric, gas, and communication facilities, together with a right of way therefor, on, over, and under the easement area as hereinafter set forth, and also ingress thereto and egress therefrom, over and across the lands of Grantor situated in the City of Fresno, County of Fresno, State of California, described as follows:

(APN 574-130-01T)

The parcel of land conveyed by Woodside 06N, LP, a California limited partnership to Grantor by deed dated April 25, 2019 and recorded as Document No. 2019-0045079, Fresno County Records.

The easement area is described as follows:

The parcel of land outlined by heavy dashed lines on the print of Grantee's Drawing No. 35433132 attached hereto and made a part hereof.

Grantor further grants to Grantee the right, from time to time, to trim or to cut down, without Grantee paying compensation, any and all trees and brush now or hereafter within said easement area, and shall have the further right, from time to time, to trim and cut down trees and brush along each side of said easement area which now or hereafter in the opinion of Grantee may interfere with or be a hazard to the facilities installed hereunder, or as Grantee deems necessary to comply with applicable state or federal regulations.

Grantor also grants to Grantee the right to use such portion of said lands contiguous to said easement area as may be reasonably necessary in connection with the excavation, construction, reconstruction, replacement, removal, maintenance and inspection of said facilities.

Grantor hereby covenants and agrees not to place or construct, nor allow a third party to place or construct, any building or other structure, or store flammable substances, or drill or operate any well, or construct any reservoir or other obstruction within said easement area, or diminish or substantially add to the ground level within said easement area, or construct any fences that will interfere with the maintenance and operation of said facilities.

Grantor further grants to Grantee the right to appportion to another public utility (as defined in Section 216 of the California Public Utilities Code) the right to excavate for, construct, reconstruct, replace, remove, maintain, inspect, and use the communications facilities within said easement area including ingress thereto and egress therefrom.

Grantor acknowledges that they have read the "Grant of Easement Disclosure Statement", Exhibit "A", attached hereto and made a part hereof.

The legal description herein, or the map attached hereto, defining the location of this utility distribution easement, was prepared by Grantee pursuant to Section 8730(c) of the Business and Professions Code.

This document may be executed in multiple counterparts, each of which shall be deemed an original, but all of which, together, shall constitute one and the same instrument.

The provisions hereof shall inure to the benefit of and bind the successors and assigns of the respective parties hereto, and all covenants shall apply to and run with the land.

Dated: _____, _____.

CLOVIS UNIFIED SCHOOL DISTRICT,
a California unified school district

By _____
Name:
Title:

By _____
Name:
Title:

I hereby certify that a resolution was adopted
on the ____ day of _____, 20 ____, by the

authorizing the foregoing grant of easement.

By _____

A notary public or other officer completing this certificate verifies only the identity of the individual who signed the document to which this certificate is attached, and not the truthfulness, accuracy, or validity of that document.

State of California
County of _____)

On _____, before me, _____ Notary Public,
Insert name

personally appeared _____

who proved to me on the basis of satisfactory evidence to be the person(s) whose name(s) is/are subscribed to the within instrument and acknowledged to me that he/she/they executed the same in his/her/their authorized capacity(ies), and that by his/her/their signature(s) on the instrument the person(s), or the entity upon behalf of which the person(s) acted, executed the instrument.

I certify under PENALTY OF PERJURY under the laws of the State of California that the foregoing paragraph is true and correct.

WITNESS my hand and official seal.

Signature of Notary Public (Seal)

CAPACITY CLAIMED BY SIGNER

- Individual(s) signing for oneself/themselves
- Corporate Officer(s) of the above named corporation(s)
- Trustee(s) of the above named Trust(s)
- Partner(s) of the above named Partnership(s)
- Attorney(s)-in-Fact of the above named Principal(s)
- Other _____



EXHIBIT "A"

GRANT OF EASEMENT DISCLOSURE STATEMENT

This Disclosure Statement will assist you in evaluating the request for granting an easement to Pacific Gas and Electric Company (PG&E) to accommodate a utility service extension to PG&E's applicant. **Please read this disclosure carefully before signing the Grant of Easement.**

- You are under no obligation or threat of condemnation by PG&E to grant this easement.
- The granting of this easement is an accommodation to PG&E's applicant requesting the extension of PG&E utility facilities to the applicant's property or project. Because this easement is an accommodation for a service extension to a single customer or group of customers, PG&E is not authorized to purchase any such easement.
- By granting this easement to PG&E, the easement area may be used to serve additional customers in the area and **may be used to install additional utility facilities**. Installation of any proposed facilities outside of this easement area will require an additional easement.
- Removal and/or pruning of trees or other vegetation on your property may be necessary for the installation of PG&E facilities. You have the option of having PG&E's contractors perform this work on your property, if available, or granting permission to PG&E's applicant or the applicant's contractor to perform this work. Additionally, in order to comply with California fire laws and safety orders, PG&E or its contractors will periodically perform vegetation maintenance activities on your property as provided for in this grant of easement in order to maintain proper clearances from energized electric lines or other facilities.
- The description of the easement location where PG&E utility facilities are to be installed across your property must be satisfactory to you.
- The California Public Utilities Commission has authorized PG&E's applicant to perform the installation of certain utility facilities for utility service. In addition to granting this easement to PG&E, your consent may be requested by the applicant, or applicant's contractor, to work on your property. Upon completion of the applicant's installation, the utility facilities will be inspected by PG&E. When the facility installation is determined to be acceptable the facilities will be conveyed to PG&E by its applicant.

By signing the Grant of Easement, you are acknowledging that you have read this disclosure and understand that you are voluntarily granting the easement to PG&E. Please return the signed and notarized Grant of Easement with this Disclosure Statement attached to PG&E. The duplicate copy of the Grant of Easement and this Disclosure Statement is for your records.

Attach to LD: 2213-21-
Area, Region or Location: 4
Land Service Office: Fresno
Line of Business: Electric Distribution (43)
Business Doc Type: Easements
MTRSQ: 22.13.21.27.33,
FERC License Number: n/a
PG&E Drawing Number: 35433132
Plat No.: 13215B (Electric)
LD of Affected Documents: n/a
LD of Cross Referenced Documents: n/a
Type of interest: Electric Underground Easements (4), Utility Easement (86)
SBE Parcel: n/a
% Being Quitclaimed: n/a
Order or PM: 35433132
JCN: n/a
County: Fresno
Utility Notice Number: n/a
851 Approval Application No: n/a ;Decision: n/a
Prepared By: m5cf
Checked By: jjwm

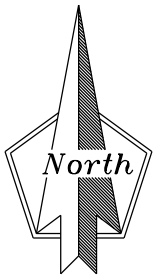

SW1/4, SW1/4
SEC. 27

GRANTOR:
CLOVIS UNIFIED SCHOOL DISTRICT
DOC. No. 2019-45079, FCR
DATED: APRIL 25, 2019
APN: 574-130-01T

PORTION OF LOT 13
BK 5 PG 14 FCR

APN: 496-220-17

N. FOWLER AVENUE

W. MCKINLEY AVENUE

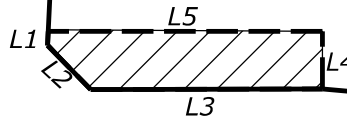

LINE TABLE

L1	S00°25'49"W (R1) 3.56'
L2	S44°36'33"E 23.24' (R1)
L3	S89°38'55"E 104.07' (R1)
L4	N00°21'05"E 20.00'
L5	N89°38'55"W (R1) 120.49'

LEGEND:

- GRANTOR'S PARCEL LINE
- PARCEL LINE
- PROPOSED EASEMENT AREA
- (R1) DOC. No. 2024-4381, FCR

POS FOR
THE SW1/4
SEC. 27 13/21

UNLESS OTHERWISE SHOWN ALL
COURSES EXTEND TO OR ALONG
ALL BOUNDARIES OR LINES

Applicant: CLOVIS UNIFIED SCHOOL DISTRICT FRESNO COUNTY CA.				SCALE NTS	DATE 6-25-24
SECTION 27	TOWNSHIP 13S	RANGE 21E	MERIDIAN MDB&M	COUNTY OF: FRESNO	CITY OF: N/A
PLAT MAP: 13215B (ELECTRIC)		REFERENCES: DOC. No. 2024-4381, FCR		F.B.: M5CF	DR.BY: M5CF CH.BY: JJWM
PG&E		FRESNO DIVISION	124911215 AUTHORIZ	35433132 DRAWING NO.	

Title: Resolution No. 4002 - Declaring Intention to Convey Easement to Fresno Metropolitan Flood Control District and Setting of Public Hearing, APNs 310-320-03ST, 310-320-05ST, 310-320-06ST, 310-050-38T

CONTACT PERSON: Michael Johnston

FOR INFORMATION:

FOR ACTION: August 7, 2024

RECOMMENDATION:

Adopt Resolution No. 4002 declaring the intention to convey an easement to Fresno Metropolitan Flood Control District (FMFCD) and set a Public Hearing for installation of a storm drain and other incidental purposes, APNs 310-320-03ST, 310-320-05ST, 310-320-06ST, 310-050-38T (TWO-THIRDS VOTE REQUIRED).

DISCUSSION:

Clovis Unified School District ("District") owns the real property located at 2501 N. Highland Avenue, Fresno, California, 93727, in the County of Fresno, and bearing Fresno County Assessor's Parcel Numbers 310-320-03ST, 310-320-05ST, 310-320-06ST, and 310-050-38T ("Property"). The District has undertaken a public works project to design and construct a new educational center including a high school and an intermediate school ("Project") on the Property. The first phase of the Project is anticipated to be completed by August 2025.

The purpose of the proposed Easement is to grant FMFCD access to the Property to install, construct, operate, maintain, repair, remove and replace an underground storm drainage pipeline and to conduct water through the same, including a right of ingress thereto and egress therefrom. The proposed Easement would prohibit the construction of any structures within the Easement area, including buildings, roof overhangs and swimming pools.

The conveyance of the easement to FMFCD is authorized by the California Education Code. Pursuant to Education Code section 17556, a school district governing board may dedicate or convey to any public corporation or private corporation engaged in the public utility business an easement to lay, construct, reconstruct, maintain, and operate water, sewer, gas, or storm drain pipes or ditches, electric or telephone lines, and access roads used in connection therewith, over and upon any land belonging to the school district, upon such terms and conditions as agreed to by the parties. Education Code section 17577 requires the governing board, by not less than a two-thirds vote of all of its board members, to adopt a resolution declaring its intention to dedicate or convey the easement and set a public hearing not less than 10 days thereafter on the question of making the conveyance.

The dedication and conveyance of an easement pursuant to Education Code section 17556 et seq. is a two-step process. At the August 7, 2024 board meeting, the Board will take action on the first step by adopting the proposed Resolution No. 4002 that is attached. By adopting the proposed Resolution, the Board would declare its intention to convey the Easement to FMFCD and set a public hearing to be held at the Board meeting on August 28, 2024. Proposed Resolution No. 4002 is attached and must be adopted by at least a two-thirds vote of all of the

Board members and be signed by the Board members or a majority thereof.

The Board actions for the second step are anticipated to occur at the Board meeting on August 28, 2024. At that meeting, the Board will: (1) hold the public hearing on the question of making the conveyance of the Easement to FMFCD; and (2) consider and adopt a resolution to approve the conveyance of the Easement to FMFCD.

FISCAL IMPACT/FUNDING SOURCE:

No fiscal impact.

ATTACHMENTS:

Description	Upload Date	Type
Resolution No. 4002	7/29/2024	Backup Material

REVISIONS:

**RESOLUTION NO. 4002
BEFORE THE GOVERNING BOARD
OF THE CLOVIS UNIFIED SCHOOL DISTRICT
FRESNO COUNTY, CALIFORNIA**

**DECLARING INTENTION TO CONVEY EASEMENT TO
FRESNO METROPOLITAN FLOOD CONTROL DISTRICT
AND SETTING OF PUBLIC HEARING**

WHEREAS, Clovis Unified School District (“District”) owns the real property located at 2501 N. Highland Avenue, Fresno, California, 93727, in the County of Fresno, and bearing Fresno County Assessor’s Parcel Numbers 310-320-03ST, 310-320-05ST, 310-320-06ST, and 310-050-38T (“Property”).

WHEREAS, The District has undertaken a public works project to design and construct a new educational center which includes a high school and an intermediate school (“Project”) on the Property. The Project is anticipated to be completed by August 2025.

WHEREAS, the District desires to grant Fresno Metropolitan Flood Control District (FMFCD) a perpetual and exclusive easement in, through, over, and under the Property to install, construct, operate, maintain, repair, remove and replace an underground storm drainage pipeline and to conduct water through the same (collectively “Utility Improvements”), including a right of ingress and egress over and across a portion of the Property, as depicted in Exhibit A (“Easement Area”). No structures, including buildings, roof overhangs and swimming pools, will be permitted or constructed within or over any drainage easement. No trees may be planted therein. Said access easement must be kept clear for potential future use.

WHEREAS, the conveyance of the Easement to FMFCD is authorized by the California Education Code. Pursuant to Education Code section 17556, a school district governing board may dedicate or convey to any public corporation or private corporation engaged in the public utility business an easement to lay, construct, reconstruct, maintain, and operate water, sewer, gas, or storm drain pipes or ditches, electric or telephone lines, and access roads used in connection therewith, over and upon any land belonging to the school district, upon such terms and conditions as agreed to by the parties.

WHEREAS, the dedication and conveyance of an easement pursuant to Education Code section 17556 et seq. is a two-step process. The first step is for the Board to adopt a resolution at a meeting of the Board declaring its intention to convey the easement and set a public hearing to

be held not less than 10 days thereafter. (Education Code § 17557) The second step is for the Board to: (1) hold the public hearing on the question of making the dedication or conveyance of the easement; and (2) adopt a resolution to authorize and direct the execution of a deed of dedication or conveyance of the easement and to deliver it. (Education Code § 17559) The resolutions must be adopted by at least a two-thirds vote of all of the Board Members. (Education Code § 17557, 17559)

WHEREAS, by this Resolution and pursuant to Education Code section 17557, the Board intends to declare its intention to convey the Easement on, across, and upon the Easement Area to FMFCD, and to fix a date and time for the public hearing upon the question of making the dedication or conveyance of the Easement to FMFCD.

THEREFORE, BE IT RESOLVED that the District's Governing Board hereby:

1. Declares and adopts the foregoing recitals as true and correct.
2. Declares its intention to convey the Easement on, across, and upon the Easement Area to FMFCD for the Utility Improvements, such an Easement as stated in Exhibit A and to be set forth in a deed of easement or other similar documents with such terms and conditions as agreed upon by the District and FMFCD.
3. Fixes the date and time of the public hearing upon the question of making the conveyance of the Easement as follows: No earlier than 6:45 p.m. on August 28, 2024, the Board shall hold a public hearing upon the question of making the conveyance of the Easement to FMFCD. The meeting shall be held at the Board's regular place of meeting, Boardroom, 1680 David E. Cook Way, Clovis, California.
4. The Superintendent or designee is authorized and directed to give notice of the adoption of this Resolution and of the time and place of holding the meeting at which the public hearing shall be conducted. The notice shall be given by posting a copy of this Resolution and by publishing written notice as required by law.
5. This Resolution shall take effect immediately upon its adoption.

THE FOREGOING RESOLUTION was adopted by the Governing Board of the Clovis Unified School District of Fresno County, California, at a regular meeting of said Board held on this 7th day of August 2024, by the following vote:

AYES:

NOES:

ABSENT:

ABSTAIN:

Hugh Awtrey, President
Governing Board
Clovis Unified School District
Fresno County, California

Member

Member

Member

Member

Member

Member

Member

I, Clinton Olivier, the Clerk of the Governing Board of the Clovis Unified School District, County of Fresno, State of California, do hereby certify that the foregoing is a true copy of the Resolution adopted by said Board at a regular meeting there, at the time and by the vote therein stated, which original resolution is on file in the office of said Board.

Clinton Olivier, Clerk
Governing Board
Clovis Unified School District
Fresno County, California

Doc# 85075, 07/2024

[ATTACH EXHIBIT A]

**RECORDING REQUESTED BY
FRESNO METROPOLITAN
FLOOD CONTROL DISTRICT**

**AND WHEN RECORDED RETURN TO:
FRESNO METROPOLITAN
FLOOD CONTROL DISTRICT
5469 East Olive Avenue
FRESNO, CALIFORNIA 93727**

--NO FEE--
Benefit of Fresno Metropolitan
Flood Control District
Pursuant to Government Codes § 6103 and 27383

SPACE ABOVE THIS LINE FOR RECORDERS USE ONLY

GRANT OF EASEMENT AND RIGHT-OF-WAY

THIS GRANT OF EASEMENT AND RIGHT-OF-WAY, is made and entered into this ___ day of _____, 20__ by and between Clovis Unified School District, a California unified school district, as Grantor, and Fresno Metropolitan Flood Control District, a California public corporation in the County of Fresno, State of California, as Grantee.

W I T N E S S E T H

That Grantor, for good and valuable consideration, does hereby grant to Grantee a perpetual and exclusive easement in, through, over, and under that real property in the County of Fresno, State of California described in Exhibit "A" (the "Easement"), attached hereto and incorporated herein by this reference, to install, construct, operate, maintain, repair, remove and replace an underground storm drainage pipeline and to conduct water through the same, together with all rights necessary, convenient or incidental thereto, including a right of ingress thereto and egress therefrom over Grantor's property as described in Exhibit "B" hereto (the "Property"), provided that such access shall not unreasonably interfere with Grantor's enjoyment of the Property.

No structures (including, but not limited to, buildings, roof overhangs and swimming pools) shall be constructed within the Easement, and no trees may be planted therein, but shrubs and grasses may be planted and sidewalks and parking areas may be installed on the Easement. In the event the Grantee damages improvements thereto in the use of reasonable care and enjoyment of the Easement, it shall not be obligated to restore the same or be liable for any damages whatsoever related thereto.

This Easement shall “run with the land” and be binding upon and inure to the benefit of Grantor’s heirs, executors, administrators, assigns and successors.

IN WITNESS WHEREOF, Grantor has executed this Grant of Easement and Right-of-Way the day and year first above written.

“GRANTOR”
Clovis Unified School District,
a California unified school district

Michael Johnston
Associate Superintendent
Administrative Services

Date

EXHIBIT "A"

LEGAL DESCRIPTION OF STORM DRAIN EASEMENT

APN: 310-320-03ST

APN: 310-320-05ST

APN: 310-320-06ST

APN: 310-050-38T

That portion of the North half of the Southeast quarter of Section 25, Township 13 South, Range 21 East, Mount Diablo Base and Meridian, County of Fresno, State of California, more particularly described as follows:

COMMENCING at the East quarter corner of said Section 25;

Thence along the east line of said Southeast quarter, South 00° 19' 00" West, a distance of 733.97 feet;

Thence North 90° 00' 00" West, a distance of 52.00 feet to the **TRUE POINT OF BEGINNING**;

Thence North 90° 00' 00" West, a distance of 1173.42 feet;

Thence South 45° 00' 00" West, a distance of 108.14 feet;

Thence North 90° 00' 00" West, a distance of 1286.57 feet;

Thence North 01° 10' 48" East, a distance of 30.01 feet;

Thence North 90° 00' 00" East, a distance of 1273.52 feet;

Thence North 45° 00' 00" East, a distance of 108.14 feet;

Thence North 90° 00' 00" East, a distance of 1172.02 feet to a line being parallel with and 66.00 feet west of said east line;

Thence along said parallel line, South 00° 19' 00" West, a distance of 1.70 feet;

Thence South 44° 49' 39" East, a distance of 19.75 feet to a line parallel with and 52.00 feet west of said east line;

Thence along said parallel line, South 00° 19' 00" West, a distance of 14.30 feet to the **TRUE POINT OF BEGINNING**.

Containing 1.766 acres more or less.

L:\PROJECTS\2021\210323\ACAD\LEGALS\ON-SITE EASEMENT\02-DWG\210323-ONSITE_EX-C.DWG 7/19/2024 9:38 AM

EAST CLINTON AVENUE ALIGNMENT

E 1/4 COR. SEC. 25-13/21

POC

D.N. 1995-142701

PARCEL MAP NO. 3250
22 PM 27

APN: 310-320-01ST
PARCEL 1

PARCEL MAP NO. 3193
21 PM 66

APN. 310-320-08ST
PARCEL 2

APN. 310-320-07ST
PARCEL 1

APN: 310-320-02ST
PARCEL 2

D.N. 2006-0103419

STORM DRAIN EASEMENT
1.766 ACRES

RIGHT OF WAY TO BE DEDICATED PER SEPARATE DOCUMENT

N90°00'00"E 1172.02'
N90°00'00"W 1173.42'

66.00'
DETAIL "A" THIS SHEET

APN. 310-320-06ST
PARCEL 2

PARCEL MAP NO. 3247
21 PM 73

PARCEL MAP NO. 3500
25 PM 60
APN: 310-320-03ST
PARCEL 1

TPOB 52.00'

N90°00'00"W 52.00'
EAST LINE SE 1/4, S25

DETAIL "A" NOT TO SCALE

LEGEND

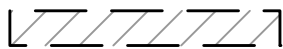

INDICATES AREA TO BE DEEDED TO FRESNO METROPOLITAN FLOOD CONTROL DISTRICT FOR STORM DRAIN EASEMENT PURPOSES. AREA = 1.766± ACRES



OVERALL SUBJECT PROPERTY LINE

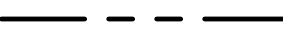

FUTURE RIGHT OF WAY



UNDERLYING/ADJACENT PROPERTY LINE

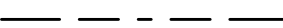

SECTION LINE

APN ASSESSOR'S PARCEL NUMBER

D.N. DOCUMENT NUMBER PER OFFICIAL RECORDS OF FRESNO COUNTY

XX PM YY BOOK XX OF PARCEL MAPS, PAGE YY, FRESNO COUNTY RECORDS

TPOB TRUE POINT OF BEGINNING

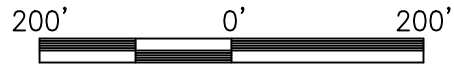
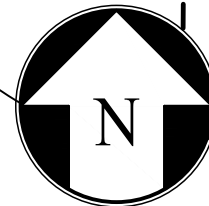
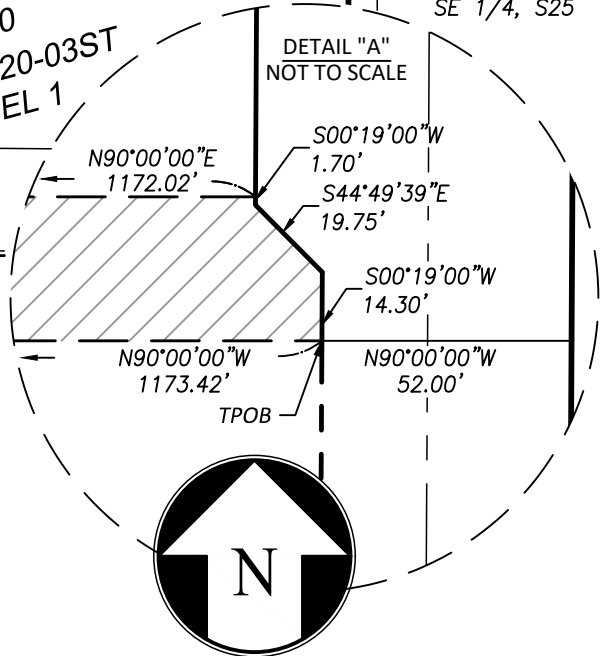

SCALE: 1" = 200'

PROJECT NO.: 210323

DRAWN BY: GAI

QA/QC BY: ASW

SCALE: AS SHOWN

PAGE NO.:

2 OF 3

EXHIBIT "A"

STORM DRAIN EASEMENT



WWW.QKINC.COM
1-800-955-7599
BAKERSFIELD, CLOVIS, HANFORD, MERCED, PORTERVILLE, VISALIA
© COPYRIGHT BY QUAD KNOPF, INC. UNAUTHORIZED USE PROHIBITED.

EAST CLINTON AVENUE ALIGNMENT

NORTH LEONARD AVENUE

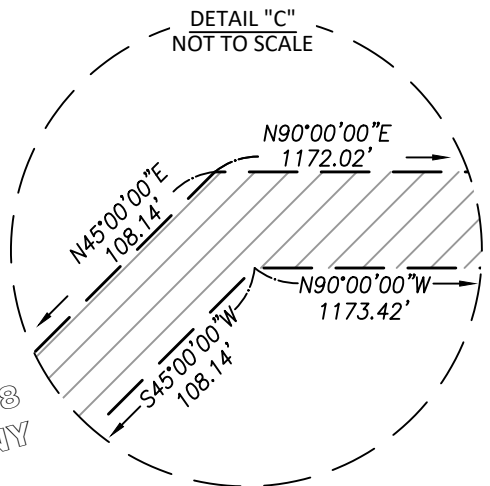
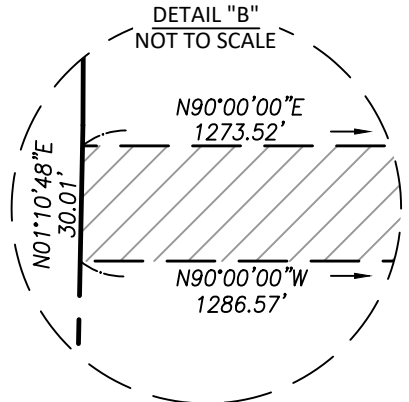

RIGHT OF WAY TO BE DEDICATED PER SEPARATE DOCUMENT

APN. 310-050-38
KUTNER COLONY
02 RS 08
LOT 8

52.00'

WEST LINE LOT 7

54.00' DETAIL "B" THIS SHEET

STORM DRAIN EASEMENT
1.766 ACRES

DETAIL "C" THIS SHEET

N90°00'00"E 1273.52'
N90°00'00"W 1286.57'



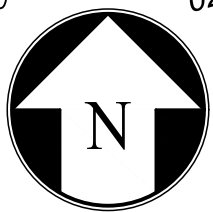



APN: 310-050-38T
KUTNER COLONY
02 RS 08
LOT 7



200' 0' 200'

SCALE: 1" = 200'

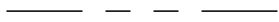
LEGEND

-  INDICATES AREA TO BE DEEDED TO FRESNO METROPOLITAN FLOOD CONTROL DISTRICT FOR STORM DRAIN EASEMENT PURPOSES. AREA = 1.766± ACRES
-  OVERALL SUBJECT PROPERTY LINE
-  FUTURE RIGHT OF WAY
-  UNDERLYING/ADJACENT PROPERTY LINE
-  EXISTING RIGHT OF WAY
-  SECTION LINE
- APN ASSESSOR'S PARCEL NUMBER
- D.N. DOCUMENT NUMBER PER OFFICIAL RECORDS OF FRESNO COUNTY.
- 02 RS 08 BOOK 02 OF RECORD OF SURVEY, PAGE 08 FRESNO COUNTY RECORDS.
- TPOB TRUE POINT OF BEGINNING

L:\PROJECTS\2021\210323\LEGAL\ON-SITE EASEMENT\02-DWG\210323-ONSITE_EX-C.DWG 7/19/2024 9:36 AM

PROJECT NO.: 210323
DRAWN BY: GAI
QA/QC BY: ASW
SCALE: AS SHOWN
PAGE NO.: 3 OF 3

EXHIBIT "A"
STORM DRAIN EASEMENT



EXHIBIT “B”

LEGAL DESCRIPTION OF PROPERTY

Those portions of the North half of the Southeast quarter of Section 25, Township 13 South, Range 21 East, Mount Diablo Base and Meridian, in the County of Fresno, State of California, more particularly described as follows:

Parcel No. 1 of Parcel Map No. 3500, according to the map thereof recorded in Book 25 Page 60 of Parcel Maps, Fresno County Records.

TOGETHER WITH Parcel No. 1 of Parcel Map No. 3247, according to the map thereof recorded in Book 21 Page 73 of Parcel Maps, Fresno County Records.

TOGETHER WITH Parcel No. 2 of Parcel Map No. 3247, according to the map thereof recorded in Book 21 Page 73 of Parcel Maps, Fresno County Records.

TOGETHER WITH Lots 7 & 8 of Kutner Colony according to the map thereof recorded in Book 2 at Page 8, of Record of Surveys, Fresno County Records.



Title: Provisional Internship Permit

CONTACT PERSON: Barry Jager

FOR INFORMATION: August 7, 2024

FOR ACTION: August 28, 2024

RECOMMENDATION:

Approve the Provisional Internship Permit for the recommended teaching candidate, as submitted.

DISCUSSION:

The Provisional Internship Permit (PIP) is available when the employing agency knows that there will be a teacher vacancy yet is unable to recruit a suitable candidate. The expectations of the employer and the employee are higher since this individual will be the teacher of record and should be on a credential track. The focus of the document is meeting subject matter competency. Once a candidate completes subject matter competency, the candidate can be employed on a document such as a District Internship Credential. Candidate requirements include the following: (1) Bachelor’s degree or higher; (2) passage of the California Basic Educational Skills Test (CBEST); and (3) specific course work or experience, explained in detail on the Provisional Internship Permit information leaflet.

As required by the California Commission on Teacher Credentialing (CCTC), employing agencies offering employment to a candidate on a Provisional Internship Permit are required to: (1) conduct a diligent search for a suitable credentialed teacher or qualified internship teacher; (2) provide the PIP holder with orientation, guidance, and assistance as specified in Title 5 Section 80026.5 of the California Code of Regulations; (3) assist the PIP holder in developing a personalized plan (kept on file at the local level) through an agency-defined assessment leading to completion of subject matter competence; and (4) counsel the PIP holder to enroll in subject matter training. Clovis Unified School District administration hereby declares that a diligent search was conducted for suitable credentialed teachers or qualified internship teachers. Upon Board approval, District administration asserts that steps 2-4, as outlined above, will be completed.

School districts submitting Provisional Internship Permit requests must include verification that a notice of intent to employ the applicants in the identified positions was made public. The public notice must include the following information: (1) the name of the applicant(s); (2) the assignment in which the applicant(s) will be employed including subject(s), grade level(s), and school site; and (3) a statement that the applicant(s) will be employed on the basis of a Provisional Internship Permit. Clovis Unified intends to submit a Provisional Internship Permit request for the following teacher candidate, contingent upon administration and Board approval:

Name of Applicant	Assignment	Grade Level	School Site	Employment Status
-------------------	------------	-------------	-------------	-------------------

Antonio Castillo	Resource Specialist	9-12	Clovis East High School	PIP (Education Specialist Mild to Moderate Support Needs)

A Provisional Internship Permit shall be issued for one year and may not be renewed.

Lastly, public school districts must include a copy of the agenda item presented to the Governing Board of the District. The agenda item must be presented in a public meeting as an Action item and include the information above for each individual for whom the permit will be requested. The permit request must include a signed statement from the Superintendent, or designee, that the item was acted upon favorably. To assure that each permit request receives individual review and approval by the Governing Board, the agenda item may not be part of the Consent agenda.

FISCAL IMPACT/FUNDING SOURCE:

REVISIONS:

CONTACT PERSON: Michael Johnston

FOR INFORMATION: August 7, 2024

FOR ACTION: August 28, 2024

RECOMMENDATION:

Approve an amendment to the District's Section 125 Flexible Benefit Plan, as submitted.

DISCUSSION:

Clovis Unified has maintained a Flexible Benefit Plan since February 1994 in order to make a broader range of benefits available to its employees and their beneficiaries. This plan allows employees to choose among different types of benefits and select the combination best suited to their individual goals, desires and needs. These choices include an option to receive certain benefits in lieu of taxable compensation. The plan helps Clovis Unified attract, reward and retain highly qualified, skilled employees.

The change to the 2024-25 plan is as follows:

- The Flex Maximum will increase from \$3,050 to \$3,200.

The revised Section 125 Flexible Benefit Plan is available for review in the Administrative Services Department.

FISCAL IMPACT/FUNDING SOURCE:

No fiscal impact

REVISIONS:

CONTACT PERSON: Marc Hammack

FOR INFORMATION: August 7, 2024

FOR ACTION: August 28, 2024

RECOMMENDATION:

Authorize the Superintendent or designee to enter into an agreement with CommonLit, a web-based toolkit, effective for a three-year period for school years 2024-25, 2025-26, and 2026-27.

DISCUSSION:

CommonLit is a digital literacy program offering engaging reading lessons, benchmark assessments, and detailed standards-based data to help teachers track progress. CommonLit will be utilized as a supplemental material for intervention and to enhance our core curriculum. Students benefit from diverse and thought-provoking texts that promote critical thinking and analytical skills. These texts will also be utilized in Curriculum Design Teams to develop district common assessments. The program includes built-in scaffolds and accessibility tools, ensuring all students can access the material, regardless of their reading level. Teachers have access to high-quality, research-backed content and structured lessons designed to reach all learners. The digital platform also features built-in professional development resources, with partnerships providing virtual training sessions for teachers and school leaders throughout the year.

FISCAL IMPACT/FUNDING SOURCE:

The fiscal impact for a three-year contract with CommonLit is \$120,750 over three years, to be included in the Curriculum, Instruction and Accountability budget.

REVISIONS:

CONTACT PERSON: Marc Hammack

FOR INFORMATION: August 7, 2024

FOR ACTION: August 28, 2024

RECOMMENDATION:

Approve the mentoring agreement with Action Mentoring Program (AMP), as submitted.

DISCUSSION:

AMP aims to support youth in bringing about positive youth development in students that have experienced or are experiencing adverse circumstances and provide mentorship and community resources to meet the needs of those students.

The overall goal and objective of AMP is to help foster a supportive learning environment and assist in facilitating the success of students' academic goals and the needs of the whole person. Through meaningful relationships and support, the mentorship program is structured to enhance student participation, increase engagement in learning, and cultivate student skills and confidence for future success.

AMP will provide mentoring services five days per week to all students enrolled in Clovis Community Day School, Clovis Online School and Gateway High School. Mentors will strive to build relationships in a manner that assists in identifying each student's unique path for development. Additionally, mentors will introduce incentives that will aim to motivate and inspire students to actively engage in and complete tasks. The incentives are carefully designed to enhance participation, sustain interest, and cultivate excitement among students.

FISCAL IMPACT/FUNDING SOURCE:

Total cost of agreement for 2024-25 school year is \$168,030, which will be funded through LCAP and Title I resources.

REVISIONS:

CONTACT PERSON: Corrine Folmer

FOR INFORMATION: August 7, 2024

FOR ACTION: August 28, 2024

RECOMMENDATION:

Should the Governing Board desire to maintain its membership in the California School Boards Association (CSBA) for the 2024-25 school year, it will be necessary for the Board to approve the payment of dues in the amount of \$26,289. For membership in the Education Legal Alliance (ELA), the Board will need to approve the payment in the amount of \$6,572.

DISCUSSION:

The 2024-25 CSBA membership dues are \$26,289, an increase of \$2,917 from 2023-24. The cost for ELA for 2024-25 is \$6,572, which is an increase of \$594 from 2023-24. The total increase for both CSBA and ELA memberships is \$3,511.

FISCAL IMPACT/FUNDING SOURCE:

Included in the 2024-25 budget, paid from the Governing Board budget.

REVISIONS:

Title: Resolution No. 4003 - Approving Conveyance of Easement to Fresno Metropolitan Flood Control District, APNs 310-320-03ST, 310-320-05ST, 310-320-06ST, 310-050-38T

CONTACT PERSON: Michael Johnston

FOR INFORMATION: August 7, 2024

FOR ACTION: August 28, 2024

RECOMMENDATION:

Adopt Resolution No. 4003 approving the conveyance of an easement to Fresno Metropolitan Flood Control District (FMFCD) for installation of a storm drain and other incidental purposes regarding APNs 310-320-03ST, 310-320-05ST, 310-320-06ST, 310-050-38T (TWO-THIRDS VOTE REQUIRED).

DISCUSSION:

Clovis Unified School District ("District") owns the real property located at 2501 N. Highland Avenue, Fresno, California, 93727, in the County of Fresno, and bearing Fresno County Assessor's Parcel Numbers 310-320-03ST, 310-320-05ST, 310-320-06ST, and 310-050-38T ("Property"). The District has undertaken a public works project to design and construct a new educational center including a high school and an intermediate school ("Project") on the Property. The first phase of the Project is anticipated to be completed by August 2025.

The purpose of the proposed Easement is to grant FMFCD access to the Property to install, construct, operate, maintain, repair, remove and replace an underground storm drainage pipeline and to conduct water through the same, including a right of ingress thereto and egress therefrom. The proposed Easement would prohibit the construction of any structures within the Easement area, including buildings, roof overhangs and swimming pools.

The conveyance of the easement to FMFCD is authorized by the California Education Code. Pursuant to Education Code section 17556, a school district governing board may dedicate or convey to any public corporation or private corporation engaged in the public utility business an easement to lay, construct, reconstruct, maintain, and operate water, sewer, gas, or storm drain pipes or ditches, electric or telephone lines, and access roads used in connection therewith, over and upon any land belonging to the school district, upon such terms and conditions as agreed to by the parties. Education Code section 17577 requires the governing board, by not less than a two-thirds vote of all of its board members, to adopt a resolution declaring its intention to dedicate or convey the easement and set a public hearing not less than 10 days thereafter on the question of making the conveyance.

The dedication and conveyance of an easement pursuant to Education Code section 17556 et seq. is a two-step process. At this August 7, 2024, Board meeting, the Board is asked to take action on the first step by adopting proposed Resolution No. 4002 declaring its intention to convey the Easement to FMFCD and set a public hearing to be held at the Board meeting on August 28, 2024. Resolution No. 4002 must be adopted by at least a two-thirds vote of all of the Board members and be signed by the Board members or a majority thereof.

The Board actions for the second step are anticipated to occur at the Board meeting on August 28, 2024. At that meeting, the Board will: (1) hold the public hearing on the question of making the conveyance of the Easement to FMFCD; and (2) consider and adopt the proposed Resolution No. 4003, attached, to approve the conveyance of the Easement to FMFCD.

FISCAL IMPACT/FUNDING SOURCE:

No fiscal impact.

ATTACHMENTS:

Description	Upload Date	Type
Resolution No. 4003	7/29/2024	Backup Material

REVISIONS:

**RESOLUTION NO. 4003
BEFORE THE GOVERNING BOARD
OF THE CLOVIS UNIFIED SCHOOL DISTRICT
FRESNO COUNTY, CALIFORNIA**

**APPROVING CONVEYANCE OF EASEMENT
AND AUTHORIZING EXECUTION OF AGREEMENT
AND ACTIONS RELATED THERETO**

GRANTEE: FRESNO METROPOLITAN FLOOD CONTROL DISTRICT (FMFCD)

**PROPERTY: APNs 310-320-03ST, 310-320-05ST, 310-320-06ST, 310-050-38T
2501 N. HIGHLAND AVENUE, FRESNO, CALIFORNIA, 93727**

WHEREAS, Clovis Unified School District (“District”) owns the Property listed above and described in Exhibit A attached hereto.

WHEREAS, The District has undertaken a public works project to design and construct a new educational center including a high school and an intermediate school (“Project”) on the Property. The Project is anticipated to be completed by August 2025.

WHEREAS, the District desires to grant Fresno Metropolitan Flood Control District (FMFCD) a perpetual and exclusive easement in, through, over, and under the Property to install, construct, operate, maintain, repair, remove and replace an underground storm drainage pipeline and to conduct water through the same (collectively “Utility Improvements”), including a right of ingress and egress over and across a portion of the Property, as depicted in Exhibit A (“Easement Area”). No structures, including buildings, roof overhangs and swimming pools, will be permitted or constructed within or over any drainage easement. No trees may be planted therein. Said access easement must be kept clear for potential future use.

WHEREAS, the conveyance of the Easement to Grantee is authorized by the California Education Code. Pursuant to Education Code section 17556, a school district governing board may dedicate or convey to any public corporation or private corporation engaged in the public utility business an easement to lay, construct, reconstruct, maintain, and operate water, sewer, gas, or storm drain pipes or ditches, electric or telephone lines, and access roads used in connection therewith, over and upon any land belonging to the school district, upon such terms and conditions as agreed to by the parties.

WHEREAS, the dedication and conveyance of an easement pursuant to Education Code section 17556 et seq. is a two-step process. The first step is for the Board to adopt a resolution at a meeting of the Board declaring its intention to convey the easement and set a public hearing to be held not less than 10 days thereafter. (Education Code § 17557) The second step is for the Board to: (1) hold the public hearing on the question of making the dedication or conveyance of the easement; and (2) adopt a resolution to authorize and direct the execution of a deed of dedication or conveyance of the easement and to deliver it. (Education Code § 17559) The resolution must be adopted by at least a two-thirds vote of all of the Board Members. (Education Code § 17557, 17559)

WHEREAS, the Board completed the first step of the process by adopting, at its Board meeting on August 7, 2024, Resolution No. 4002 declaring its intention to convey the Easement to Grantee and setting a public hearing to be held at the Board meeting on August 28, 2024.

WHEREAS, at the Board meeting on August 28, 2024, the Board will take action to complete the second step in the process by adopting this Resolution and approving and authorizing the actions set forth below.

WHEREAS, no protest has been filed under Education Code section 17560.

THEREFORE, BE IT RESOLVED that the District’s Governing Board hereby:

1. Declares and adopts the foregoing recitals as true and correct.
2. Pursuant to Education Code section 17556 et seq., approves the conveyance of the Easement on, across, and upon the Easement Area to Grantee as set forth in the agreement between Grantee and District (“Easement Agreement”).
3. Authorizes and directs the Superintendent or designee to: (1) execute and deliver to Grantee the Easement Agreement and other documents as may be necessary to convey the Easement to Grantee, with such modifications thereto as the Superintendent or designee determines appropriate and agreed upon with Grantee; and (2) take such actions and execute such other documents as may be necessary to carry out and complete the Easement Agreement and the transaction contemplated by this Resolution.
4. This Resolution shall take effect immediately upon its adoption.

THE FOREGOING RESOLUTION was adopted by the Governing Board of the Clovis Unified School District of Fresno County, California, at a regular meeting of said Board held on this 28th day of August, 2024 by the following vote:

AYES:

NOES:

ABSENT:

ABSTAIN:

Hugh Awtrey, President
Governing Board
Clovis Unified School District
Fresno County, California

I, Clinton Olivier, the Clerk of the Governing Board of the Clovis Unified School District, County of Fresno, State of California, do hereby certify that the foregoing is a true copy of the Resolution adopted by said Board at a regular meeting there, at the time and by the vote therein stated, which original resolution is on file in the office of said Board.

Clinton Olivier, Clerk
Governing Board
Clovis Unified School District
Fresno County, California

Doc# 85088, 07/2024

[ATTACH EXHIBIT A]

**RECORDING REQUESTED BY
FRESNO METROPOLITAN
FLOOD CONTROL DISTRICT**

**AND WHEN RECORDED RETURN TO:
FRESNO METROPOLITAN
FLOOD CONTROL DISTRICT
5469 East Olive Avenue
FRESNO, CALIFORNIA 93727**

--NO FEE--
Benefit of Fresno Metropolitan
Flood Control District
Pursuant to Government Codes § 6103 and 27383

SPACE ABOVE THIS LINE FOR RECORDERS USE ONLY

GRANT OF EASEMENT AND RIGHT-OF-WAY

THIS GRANT OF EASEMENT AND RIGHT-OF-WAY, is made and entered into this ___ day of _____, 20__ by and between Clovis Unified School District, a California unified school district, as Grantor, and Fresno Metropolitan Flood Control District, a California public corporation in the County of Fresno, State of California, as Grantee.

W I T N E S S E T H

That Grantor, for good and valuable consideration, does hereby grant to Grantee a perpetual and exclusive easement in, through, over, and under that real property in the County of Fresno, State of California described in Exhibit "A" (the "Easement"), attached hereto and incorporated herein by this reference, to install, construct, operate, maintain, repair, remove and replace an underground storm drainage pipeline and to conduct water through the same, together with all rights necessary, convenient or incidental thereto, including a right of ingress thereto and egress therefrom over Grantor's property as described in Exhibit "B" hereto (the "Property"), provided that such access shall not unreasonably interfere with Grantor's enjoyment of the Property.

No structures (including, but not limited to, buildings, roof overhangs and swimming pools) shall be constructed within the Easement, and no trees may be planted therein, but shrubs and grasses may be planted and sidewalks and parking areas may be installed on the Easement. In the event the Grantee damages improvements thereto in the use of reasonable care and enjoyment of the Easement, it shall not be obligated to restore the same or be liable for any damages whatsoever related thereto.

This Easement shall “run with the land” and be binding upon and inure to the benefit of Grantor’s heirs, executors, administrators, assigns and successors.

IN WITNESS WHEREOF, Grantor has executed this Grant of Easement and Right-of-Way the day and year first above written.

“GRANTOR”
Clovis Unified School District,
a California unified school district

Michael Johnston
Associate Superintendent
Administrative Services

Date

EXHIBIT "A"

LEGAL DESCRIPTION OF STORM DRAIN EASEMENT

APN: 310-320-03ST

APN: 310-320-05ST

APN: 310-320-06ST

APN: 310-050-38T

That portion of the North half of the Southeast quarter of Section 25, Township 13 South, Range 21 East, Mount Diablo Base and Meridian, County of Fresno, State of California, more particularly described as follows:

COMMENCING at the East quarter corner of said Section 25;

Thence along the east line of said Southeast quarter, South 00° 19' 00" West, a distance of 733.97 feet;

Thence North 90° 00' 00" West, a distance of 52.00 feet to the **TRUE POINT OF BEGINNING**;

Thence North 90° 00' 00" West, a distance of 1173.42 feet;

Thence South 45° 00' 00" West, a distance of 108.14 feet;

Thence North 90° 00' 00" West, a distance of 1286.57 feet;

Thence North 01° 10' 48" East, a distance of 30.01 feet;

Thence North 90° 00' 00" East, a distance of 1273.52 feet;

Thence North 45° 00' 00" East, a distance of 108.14 feet;

Thence North 90° 00' 00" East, a distance of 1172.02 feet to a line being parallel with and 66.00 feet west of said east line;

Thence along said parallel line, South 00° 19' 00" West, a distance of 1.70 feet;

Thence South 44° 49' 39" East, a distance of 19.75 feet to a line parallel with and 52.00 feet west of said east line;

Thence along said parallel line, South 00° 19' 00" West, a distance of 14.30 feet to the **TRUE POINT OF BEGINNING**.

Containing 1.766 acres more or less.

L:\PROJECTS\2021\210323\ACAD\LEGALS\ON-SITE EASEMENT\02-DWG\210323-ONSITE_EX-C.DWG 7/19/2024 9:38 AM

EAST CLINTON AVENUE ALIGNMENT

E 1/4 COR. SEC. 25-13/21

POC

D.N. 1995-142701

PARCEL MAP NO. 3250
22 PM 27

APN: 310-320-01ST
PARCEL 1

PARCEL MAP NO. 3193
21 PM 66

APN. 310-320-08ST
PARCEL 2

APN. 310-320-07ST
PARCEL 1

APN: 310-320-02ST
PARCEL 2

D.N. 2006-0103419

STORM DRAIN EASEMENT
1.766 ACRES

RIGHT OF WAY TO BE DEDICATED PER SEPARATE DOCUMENT

N90°00'00"E 1172.02'
N90°00'00"W 1173.42'

66.00'
DETAIL "A" THIS SHEET

N90°00'00"W 52.00'

EAST LINE SE 1/4, S25

TPOB 52.00'

DETAIL "A" NOT TO SCALE

APN. 310-320-06ST
PARCEL 2

PARCEL MAP NO. 3247
21 PM 73

PARCEL MAP NO. 3500
25 PM 60
APN: 310-320-03ST
PARCEL 1

APN. 310-320-05ST
PARCEL 1

LEGEND

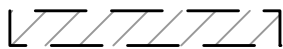

INDICATES AREA TO BE DEEDED TO FRESNO METROPOLITAN FLOOD CONTROL DISTRICT FOR STORM DRAIN EASEMENT PURPOSES. AREA = 1.766± ACRES



OVERALL SUBJECT PROPERTY LINE

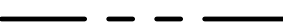

FUTURE RIGHT OF WAY



UNDERLYING/ADJACENT PROPERTY LINE



SECTION LINE

APN ASSESSOR'S PARCEL NUMBER

D.N. DOCUMENT NUMBER PER OFFICIAL RECORDS OF FRESNO COUNTY

XX PM YY BOOK XX OF PARCEL MAPS, PAGE YY, FRESNO COUNTY RECORDS

TPOB TRUE POINT OF BEGINNING

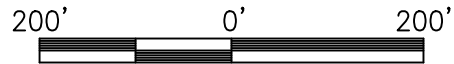
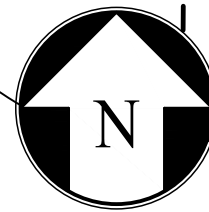
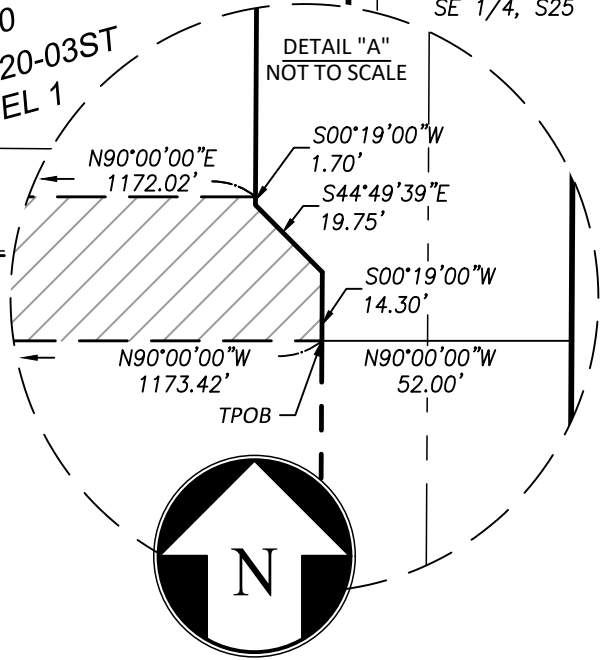

SCALE: 1" = 200'

PROJECT NO.:	210323
DRAWN BY:	GAJ
QA/QC BY:	ASW
SCALE:	AS SHOWN
PAGE NO.:	2 OF 3

EXHIBIT "A"
STORM DRAIN EASEMENT

WWW.QKINC.COM
1-800-955-7599
BAKERSFIELD, CLOVIS, HANFORD, MERCED, PORTERVILLE, VISALIA
© COPYRIGHT BY QUAD KNOPF, INC. UNAUTHORIZED USE PROHIBITED.

EAST CLINTON AVENUE ALIGNMENT

NORTH LEONARD AVENUE

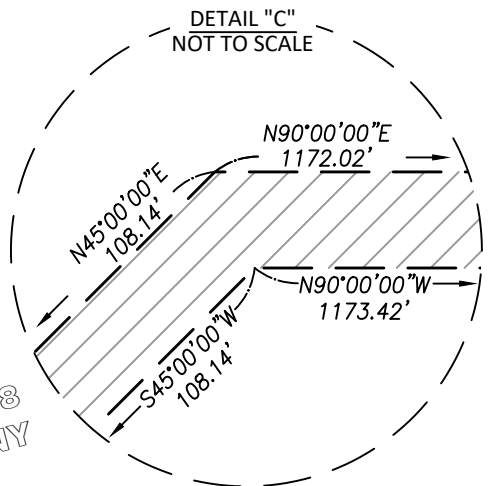
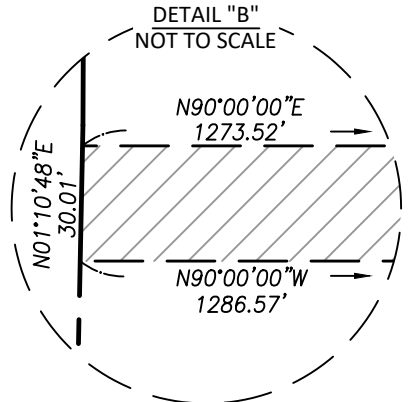

RIGHT OF WAY TO BE DEDICATED PER SEPARATE DOCUMENT

APN. 310-050-38
KUTNER COLONY
02 RS 08
LOT 8

52.00'

WEST LINE LOT 7

54.00' DETAIL "B" THIS SHEET

STORM DRAIN EASEMENT
1.766 ACRES

DETAIL "C" THIS SHEET

N90°00'00"E 1273.52'
N90°00'00"W 1286.57'



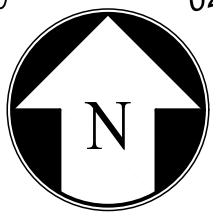



APN: 310-050-38T
KUTNER COLONY
02 RS 08
LOT 7



200' 0' 200'

SCALE: 1" = 200'

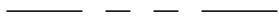
LEGEND

-  INDICATES AREA TO BE DEEDED TO FRESNO METROPOLITAN FLOOD CONTROL DISTRICT FOR STORM DRAIN EASEMENT PURPOSES. AREA = 1.766± ACRES
-  OVERALL SUBJECT PROPERTY LINE
-  FUTURE RIGHT OF WAY
-  UNDERLYING/ADJACENT PROPERTY LINE
-  EXISTING RIGHT OF WAY
-  SECTION LINE
- APN ASSESSOR'S PARCEL NUMBER
- D.N. DOCUMENT NUMBER PER OFFICIAL RECORDS OF FRESNO COUNTY.
- 02 RS 08 BOOK 02 OF RECORD OF SURVEY, PAGE 08 FRESNO COUNTY RECORDS.
- TPOB TRUE POINT OF BEGINNING

L:\PROJECTS\2021\210323\LEGAL\ON-SITE EASEMENT\02-DWG\210323-ONSITE_EX-C.DWG 7/19/2024 9:36 AM

PROJECT NO.: 210323
 DRAWN BY: GAI
 QA/QC BY: ASW
 SCALE: AS SHOWN
 PAGE NO.:
3 OF 3

EXHIBIT "A"

STORM DRAIN EASEMENT



www.qkinc.com
1-800-955-7599
BAKERSFIELD, CLOVIS, HANFORD, MERCED, PORTERVILLE, VISALIA
© COPYRIGHT BY QUAD KNOPF, INC. UNAUTHORIZED USE PROHIBITED.

EXHIBIT “B”

LEGAL DESCRIPTION OF PROPERTY

Those portions of the North half of the Southeast quarter of Section 25, Township 13 South, Range 21 East, Mount Diablo Base and Meridian, in the County of Fresno, State of California, more particularly described as follows:

Parcel No. 1 of Parcel Map No. 3500, according to the map thereof recorded in Book 25 Page 60 of Parcel Maps, Fresno County Records.

TOGETHER WITH Parcel No. 1 of Parcel Map No. 3247, according to the map thereof recorded in Book 21 Page 73 of Parcel Maps, Fresno County Records.

TOGETHER WITH Parcel No. 2 of Parcel Map No. 3247, according to the map thereof recorded in Book 21 Page 73 of Parcel Maps, Fresno County Records.

TOGETHER WITH Lots 7 & 8 of Kutner Colony according to the map thereof recorded in Book 2 at Page 8, of Record of Surveys, Fresno County Records.

CONTACT PERSON: Barry Jager

FOR INFORMATION: August 7, 2024

FOR ACTION: August 28, 2024

RECOMMENDATION:

Adopt Resolution No. 4004, approving an exemption to the separation-from-service requirement for the 2024-25 school year (Education Code § 24214.5 or 26812).

DISCUSSION:

California Education Code sections 24214.5 or 26812 authorizes the Governing Board to permit a 180-calendar-day separation-from-service requirement for all retired CalSTRS members and participants receiving an annuity. There is, however, a narrow exemption from the 180-calendar-day separation-from-service requirement if the retired member is appointed to a critically needed position.

At this time, the District is in critical need of English as a Second Language (ESL) teachers to provide services to students and collaborate with educators, parents and other professionals to create a safe, healthy and supportive learning environment. Currently, a shortage of ESL teachers exists nationwide, statewide and districtwide.

Recommended for this position is retired veteran teacher Melanie Franz who served the District for 30 years. Ms. Franz is a credentialed teacher who would be able to provide critical services for our ESL students. Due to growth and the existing shortage, there is a critical need to utilize a qualified retiree working outside the scope of her previous position. It is recommended that the Governing Board meet this critical need by requesting an exemption to the 180-day wait period for a CalSTRS retiree.

FISCAL IMPACT/FUNDING SOURCE:

ATTACHMENTS:

Description	Upload Date	Type
Resolution No. 4004	8/1/2024	Backup Material

REVISIONS:

**RESOLUTION NO. 4004
BEFORE THE GOVERNING BOARD
OF THE CLOVIS UNIFIED SCHOOL DISTRICT
FRESNO COUNTY, CALIFORNIA**

**RESOLUTION FOR THE EXEMPTION TO THE SEPARATION
FROM SERVICE REQUIREMENT FOR THE 2024-25 SCHOOL YEAR
(Education Code §24214.5 or 26812)**

WHEREAS, pursuant to Education Code sections 24214.5 or 26812, there is a 180-calendar-day separation-from-service requirement for all retired CalSTRS members and participants; and

WHEREAS, all retired CalSTRS members and participants are subject to a restriction if they perform retired member activities as defined by section 22164.5 of the Education Code or retired participant activities as defined by section 26135.7 of the Education Code, during the first 180 calendar days after their most recent retirement; and

WHEREAS, if the retired CalSTRS member or participant performed retired member or participant activities during this period, CalSTRS will reduce his or her retirement benefit or annuity one dollar for each dollar earned for performing retired member or participant activities during the 180-day period; and

WHEREAS, there is an exemption from the 180-calendar-day separation-from-service-requirement for a member or participant who retires from service and is at or above normal retirement age; and

WHEREAS, in order to qualify for this narrow exemption, the employer must appoint the retired member or participant to a crucially needed position that has been approved by the governing body of the employer in a public meeting as reflected in a resolution; and

WHEREAS, this approval by the governing body of the employer in a public meeting as reflected in a resolution must be finalized and communicated to CalSTRS before the member or participant commences to perform retired member or participant activities; and

WHEREAS, the Superintendent must complete the Request for Separation-from-Service-Requirement Exemption Form, which must be submitted to CalSTRS and received by CalSTRS before the member or participant commences to perform retired member or participant activities.

THEREFORE, BE IT RESOLVED that this Board does provide public notice that the District is in critical need of teachers in the specialized field of English as a Second Language (ESL) for Clovis Adult Education. Recommended for this position is veteran teacher Melanie Franz, who served the District for 30 years. Ms. Franz is a credentialed teacher that will provide instruction in ESL as part of our multi-level class which serves all levels of students as they enter our leveled ESL classes. In addition, Ms. Franz will provide services in our Adult Basic Education classes to further support our students at Clovis Adult Education. This critical need is paramount for the continued growth and development of our adult learners who rely on high-quality ESL education to improve their career prospects and integration into the community. Therefore, it is recommended that the Governing Board meets this critical need by requesting an exemption to the 180-day wait period for a CalSTRS retiree.

BE IT ALSO RESOLVED that the Board wishes to meet this critical need by hiring Melanie Franz, a member or participant who retired for service less than 180 days ago.

BE IT ALSO RESOLVED that this appointment is needed to fill this critical need before the 180-calendar-day separation-from-service requirement is fulfilled.

BE IT ALSO RESOLVED that this member or participant did not receive a retirement incentive or any financial inducement to retire from any public employer.

BE IT ALSO RESOLVED that the retired member's or participant's termination of employment is not the basis for the need to acquire his or her services.

BE IT ALSO RESOLVED that the earnings for retired member activities during the 180 calendar days will still be subject to the annual postretirement earnings limit for the Defined Benefit Program.

BE IT ALSO RESOLVED that this member or participant will not commence to perform retired member or participant activities before this approval is authorized by the governing body of the employer in a public meeting as reflected in a resolution and received by CalSTRS.

BE IT ALSO RESOLVED that this member or participant will not commence to perform retired member or participant activities before the Superintendent completes the Request for Separation-from-Service Requirement Exemption Form and this is transmitted to and received by CalSTRS.

THE FOREGOING RESOLUTION was adopted by the Governing Board of the Clovis Unified School District of Fresno County, State of California, at a regular meeting of said Board duly held on this 28th day of August, 2024, by the following vote:

AYES:

NOES:

ABSENT:

ABSTAIN:

Hugh Awtrey, President
Governing Board
Clovis Unified School District
Fresno County, California

I, Clinton Olivier, Clerk of the Governing Board of the Clovis Unified School District, County of Fresno, State of California, do hereby certify that the foregoing is a true copy of the resolution adopted by said Board at as regular meeting thereof, at the time and by the vote therein stated, which original resolution is on file in the office of said Board.

Clinton Olivier, Clerk
Governing Board
Clovis Unified School District
Fresno County, California

CONTACT PERSON: Barry Jager

FOR INFORMATION: August 7, 2024

FOR ACTION: August 28, 2024

RECOMMENDATION:

Adopt Resolutions No. 4005 and 4006 authorizing Clovis Unified School District to hire two CalPERS retirees prior to the 180-day post-retirement waiting period.

DISCUSSION:

A retiree can return to work for a school district employer without reinstating into active service and without an impact on their pension benefit if they return to work for one of the following reasons (Government Code Section 7522.56):

- An emergency to prevent stoppage of public business.
- The retiree has skills needed to perform work of limited duration.

A public agency retiree cannot return to work for at least 180 days after retirement unless the following conditions are met (Government Code 7522.56):

- The employer certifies that the appointment is necessary to fill a critically needed position before 180 days have passed.
- The appointment has been approved by the governing body of the employer in a public meeting.

The District deems it essential to appoint retirees John Meyers and Luis Galindo to fulfill the vital role of Student Resource Officers, which are currently vacant and urgently required. These positions carry the responsibility of providing critical safety needs for our schools and community. The District remains actively engaged in recruiting for these positions. Officers Meyers and Galindo possess the necessary experience and expertise to carry out these responsibilities until the vacancies are filled. It is important to note that the employment of these retirees will be restricted to 960 hours per officer for the 2024-25 fiscal year.

FISCAL IMPACT/FUNDING SOURCE:

No fiscal impact.

ATTACHMENTS:

Description	Upload Date	Type
Resolution No. 4005	7/31/2024	Backup Material
Resolution No. 4006	7/31/2024	Backup Material

REVISIONS:

**RESOLUTION NO. 4005
BEFORE THE GOVERNING BOARD
OF THE CLOVIS UNIFIED SCHOOL DISTRICT
FRESNO COUNTY, CALIFORNIA**

**RESOLUTION FOR THE EXEMPTION TO THE
SEPARATION-FROM-SERVICE REQUIREMENT
FOR THE 2024-25 SCHOOL YEAR
(Government Code § 7522.56 and 21221)**

WHEREAS, in compliance with Government Code section 7522.56 of the Public Employees' Retirement Law, the Clovis Unified School District's Governing Board must provide CalPERS this certification resolution when hiring a retiree before 180 days have passed since his or her retirement date; and

WHEREAS, John Meyers (ID No. 1621) retired from Clovis Unified School District in the position of School Resource Officer, effective June 7, 2024; and

WHEREAS, Government Code section 7522.56 requires that post-retirement employment commence no earlier than 180 days after the retirement date, which is December 5, 2024, without this certification resolution; and

WHEREAS, Government Code section 7522.56 provides that this exception to the 180-day wait period shall not apply if the retiree accepts any retirement-related incentive; and

WHEREAS, the Clovis Unified School District and John Meyers certify that John Meyers has not and will not receive a Golden Handshake or any other retirement-related incentive; and

WHEREAS, the Clovis Unified School District hereby appoints John Meyers as an interim appointment retired annuitant to the vacant position of School Resource Officer for the Clovis Unified School District under Government Code section 21221(h), effective August 29, 2024; and

WHEREAS, an appointment under Government Code section 21221(h) requires an active, publicly posted recruitment for a permanent replacement; and

WHEREAS, the current status of this recruitment is ongoing, in process and posted with insufficient applicants; and

WHEREAS, this Government Code section 21221(h) appointment shall only be made once and therefore will end on June 6, 2025; and

WHEREAS, the entire employment agreement, contract or appointment document between John Meyers and the Clovis Unified School District has been reviewed by this body and is attached herein; and

WHEREAS, no matters, issues, terms or conditions related to this employment and appointment have been or will be placed on a consent calendar; and

WHEREAS, the employment shall be limited to 960 hours per fiscal year; and

WHEREAS, the compensation paid to retirees cannot be less than the minimum nor exceed the maximum monthly base salary paid to other employees performing comparable duties, divided by 173.333 to equal the hourly rate; and

WHEREAS, the maximum base salary for this position is \$6,211.80 and the hourly equivalent is \$35.70 and the minimum base salary for this position is \$5,115.60 and the hourly equivalent is \$29.40; and

WHEREAS, the hourly rate paid to John Meyers will be \$35.70; and

WHEREAS, John Meyers has not and will not receive any other benefit, incentive, compensation in lieu of benefit or other form of compensation in addition to this hourly pay rate.

THEREFORE, BE IT RESOLVED THAT the Clovis Unified School District's Governing Board hereby certifies the nature of the employment of John Meyers as described herein and detailed in the attached employment requisition and that this appointment is necessary to fill the critically needed position of Student Resource Officer for the Clovis Unified School District by August 29, 2024. This position provides a critical safety need for our schools and community and the work is necessary to fill these positions sooner than the 180 days. The work performed will be peace officer annuitant work.

THE FOREGOING RESOLUTION was adopted by the Governing Board of the Clovis Unified School District of Fresno County, state of California, at a regular meeting of said Board held on this 28th day of August, 2024, by the following vote:

AYES:

NOES:

ABSENT:

ABSTAIN:

Hugh Awtrey, President
Governing Board
Clovis Unified School District
Fresno County, California

I, Clinton Olivier, Clerk of the Governing Board of the Clovis Unified School District, County of Fresno, State of California, do hereby certify that the foregoing is a true copy of the resolution adopted by said Board at as regular meeting thereof, at the time and by the vote therein stated, which original resolution is on file in the office of said Board.

Clinton Olivier, Clerk
Governing Board
Clovis Unified School District
Fresno County, California

**RESOLUTION NO. 4006
BEFORE THE GOVERNING BOARD
OF THE CLOVIS UNIFIED SCHOOL DISTRICT
FRESNO COUNTY, CALIFORNIA**

**RESOLUTION FOR THE EXEMPTION TO THE SEPARATION
FROM SERVICE REQUIREMENT FOR THE 2024-25 SCHOOL YEAR
(G.C Sections §7522.56 & 21224)**

WHEREAS, in compliance with Government Code section 7522.56 of the Public Employees' Retirement Law, Clovis Unified School District's Governing Board must provide CalPERS this certification resolution when hiring a retiree before 180 days has passed since his or her retirement date; and

WHEREAS, Luis Galindo (ID No. 9876) retired from Clovis Unified School District in the position of School Resource Officer effective July 3, 2024; and

WHEREAS, Government Code section 7522.56 requires that post-retirement employment commence no earlier than 180 days after the retirement date, which is December 31, 2024, without this certification resolution; and

WHEREAS, Government Code section 7522.56 provides that this exception to the 180-day wait period shall not apply if the retiree accepts any retirement-related incentive; and

WHEREAS, the Clovis Unified School District and Luis Galindo certify that Luis Galindo has not and will not receive a Golden Handshake or any other retirement-related incentive; and

WHEREAS, the Clovis Unified School District hereby appoints Luis Galindo as an interim appointment retired annuitant to the vacant position of School Resource Officer for the Clovis Unified School District under Government Code section 21221(h), effective August 29, 2024; and

WHEREAS, an appointment under Government Code section 21221(h) requires an active, publicly posted recruitment for a permanent replacement; and

WHEREAS, the current status of this recruitment is ongoing, in process and posted with insufficient applicants; and

WHEREAS, this Government Code section 21221(h) appointment shall only be made once and therefore will end on June 6, 2025; and

WHEREAS, the entire employment agreement, contract or appointment document between Luis Galindo and the Clovis Unified School District has been reviewed by this body and is attached herein; and

WHEREAS, no matters, issues, terms or conditions related to this employment and appointment have been or will be placed on a consent calendar; and

WHEREAS, the employment shall be limited to 960 hours per fiscal year; and

WHEREAS, the compensation paid to retirees cannot be less than the minimum nor exceed the maximum monthly base salary paid to other employees performing comparable duties, divided by 173.333 to equal the hourly rate; and

WHEREAS, the maximum base salary for this position is \$6,211.80 and the hourly equivalent is \$35.70 and the minimum base salary for this position is \$5,115.60 and the hourly equivalent is \$29.40; and

WHEREAS, the hourly rate paid to Luis Galindo will be \$35.70; and

WHEREAS, Luis Galindo has not and will not receive any other benefit, incentive, compensation in lieu of benefit or other form of compensation in addition to this hourly pay rate.

THEREFORE, BE IT RESOLVED THAT the Clovis Unified School District's Governing Board hereby certifies the nature of the employment of Luis Galindo as described herein and detailed in the attached employment requisition and that this appointment is necessary to fill the critically needed position of Student Resource Officer for the Clovis Unified School District by August 29, 2024. This position provides a critical safety need for our schools and community and the work is necessary to fill these positions sooner than the 180 days. The work performed will be peace officer annuitant work.

THE FOREGOING RESOLUTION was adopted by the Governing Board of the Clovis Unified School District of Fresno County, California, at a regular meeting of said Board duly held on this 28th day of August, 2024, by the following vote:

AYES:

NOES:

ABSENT:

ABSTAIN:

Hugh Awtrey, President
Governing Board
Clovis Unified School District
Fresno County, California

I, Clinton Olivier, Clerk of the Governing Board of the Clovis Unified School District, County of Fresno, State of California, do hereby certify that the foregoing is a true copy of the resolution adopted by said Board at as regular meeting thereof, at the time and by the vote therein stated, which original resolution is on file in the office of said Board.

Clinton Olivier, Clerk
Governing Board
Clovis Unified School District
Fresno County, California

CONTACT PERSON: Michael Johnston

FOR INFORMATION: August 7, 2024

FOR ACTION: August 28, 2024

RECOMMENDATION:

Recommendation for RFP 2998 - Charter Bus Services will be brought to the Governing Board for Action at a future date.

DISCUSSION:

Bid/ RFP #	Description	First Bid Advertisement Date	Bid Due Date and Time	Funding Source
2998	Charter Bus Services	07/24/2024	08/07/2024 10:00 AM	Varies by Usage

FISCAL IMPACT/FUNDING SOURCE:

As noted above.

REVISIONS: